

COLLECTIONS
COLLEZIONI



COLLECTIONS
COLLEZIONI

“THE WORLD NEEDS MORE
COLOUR RIGHT NOW,
DOESN'T IT?”

Il colore scelto come tratto estetico distintivo.

Quintessenza, azienda ceramica, specializzata sul piccolo formato, nei suoi 10 anni di attività compie un processo evolutivo che vede protagonista il colore. Si è partiti da un'elegante sobrietà delle prime collezioni data da toni neutri e colori pastello, per poi introdurre finiture metallizzate, nuance sfumate e colori più intensi e decisi.

La sperimentazione non si limita alla scelta di una palette cromatica, ma l'obiettivo è creare equilibrate alchimie estetiche tra le diverse collezioni per realizzare un ambiente coordinato pavimento/ rivestimento. L'esperienza acquisita nello studio sul colore ci ha permesso di creare una guida contenente: una selezione di stucchi in cadenza e a contrasto, diverse soluzioni di posa con pattern e riferimenti colore NCS.

EMBRACING COLOUR AS A DISTINCTIVE STYLE FEATURE

In its 10 years of existence, Quintessenza, the ceramic company specialised in small format tiles, has developed a unique process in which colour plays the leading role. This began with the elegant sobriety of its first collections with their neutral tones and pastel colours, and then progressed to metallic finishes, shaded nuances and more intense and decisive colours.

Experimentation is not limited to the choice of a colour palette, as our aim is to develop balanced aesthetic alchemies between different collections that create environments with perfect floor-wall coordination. Our experience in colour research has also allowed us to create a guide containing a selection of coordinated and contrasting grouts, as well as different laying solutions with patterns and NCS colour references.

LA COULEUR CHOISIE COMME ÉLÉMENT ESTHÉTIQUE DISTINCTIF

Quintessenza, entreprise céramique spécialisée dans les petits formats, a connu au cours de ses 10 années d'activité un processus évolutif qui voit la couleur comme protagoniste. Nous sommes partis de la sobriété élégante des premières collections donnée par des tons neutres et des couleurs pastel, pour ensuite introduire des finitions métalliques, des nuances variées et des couleurs plus intenses et décisives.

L'expérimentation ne se limite pas au choix d'une palette de couleurs, mais l'objectif est de créer des alchimies esthétiques équilibrées entre les différentes collections pour créer un environnement sol/revêtement coordonné. L'expérience acquise dans l'étude de la couleur nous a permis de créer un guide contenant: une sélection de fillers assortis et contrastés, différentes solutions de pose avec motifs NCS et références de couleurs.

"Miscelare forme e colori, texture e superfici, materia e disegno, ecco quello che facciamo ogni giorno. Per emozionare, stupire, accendere scintille di creatività."

La ricerca sul prodotto evolve sempre più: si sperimentano nuovi stili, forme e strutture che conducono ad una sofisticata tridimensionalità ceramica. Superfici in gres e pasta bianca sono frutto della progettazione sviluppata come punto di incontro tra minimalismo e decorazione, tradizione e contemporaneità, estro creativo e rigore geometrico.

Grazie al giusto mix di questi elementi nasce un'identità unica e ben definita che permette di soddisfare le esigenze progettuali di architetti ed interior designer offrendo la possibilità di attingere ad un contenitore eterogeneo: un'unica grande collezione.

"COMBINING SHAPES AND COLOURS, TEXTURES AND SURFACES, MATERIALS AND PATTERNS IS WHAT WE DO EVERY DAY. TO EXCITE, AMAZE AND IGNITE SPARKS OF CREATIVITY."

"MÉLANGER LES FORMES ET LES COULEURS, LES TEXTURES ET LES SURFACES, LA MATIÈRE ET LE DESIGN, C'EST CE QUE NOUS FAISONS CHAQUE JOUR. POUR ÉMOTIONNER, SURPRENDRE, ALLUMER DES ÉTINCELLES DE CRÉATIVITÉ"

Our product research is constantly evolving and our experiments with new styles, shapes and textures create a sophisticated ceramic three-dimensionality. Our porcelain stoneware and white body surfaces are the result of careful design, developed through a combination of minimalism and decoration, traditional and contemporary design, creative flair and geometrical precision.

La recherche de produits évolue de plus en plus: de nouveaux styles, formes et structures sont expérimentés qui conduisent à une tridimensionnalité céramique sophistiquée. Les surfaces en grès et en pâte blanche sont le résultat d'un design développé comme un point de rencontre entre minimalisme et décoration, tradition et contemporanéité, esprit créatif et rigueur géométrique.

The correct combination of these elements has given life to a unique, well-defined identity that satisfies the design requirements of architects and interior designers by offering them the chance to choose from a single grand collection.

Grâce au bon mélange de ces éléments naît une identité unique et bien définie qui nous permet de satisfaire les besoins de conception des architectes et des décorateurs d'intérieur en offrant la possibilité de s'appuyer sur un contenu hétérogène: comme une seule grande collection.



Ogni collezione ha la sua storia.

Dietro ogni collezione ceramica ideata da Ramona, co-founder di Quintessenza, c'è un'ispirazione o una vera e propria storia. Nasce la voglia di raccontare le collezioni partendo dall'ispirazione iniziale fino ad arrivare al prodotto finito, sviluppando il progetto creativo attraverso uno storytelling per coinvolgere ed emozionare.

La costante ricerca sulle nuove tendenze ci mette in relazione con il design d'autore: nasce così la prima collaborazione con la colorista e designer d'interni, Tekla Evelina Severin. Questa contaminazione porta un valore aggiunto: la raffinatezza di Quintessenza Ceramiche rimane ma con uno spirito più metafisico.

EVERY COLLECTION HAS ITS OWN STORY

Every ceramic collection designed by Ramona, the co-founder of Quintessenza, has its own special inspiration or story. We have therefore decided to recount our collections, from their initial inspiration right up to the finished product. This creative project has a gripping narrative that is specifically designed to engage and excite.

Our constant research into new trends connects us with signature design. This is how our first collaboration with the colourist and interior designer, Tekla Evelina Severin, began. This fusion creates added value, as the sophistication of Quintessenza Ceramiche remains, but with a distinctively metaphysical spirit.

CHAQUE COLLECTION A SON HISTOIRE

Derrière chaque collection conçue par Ramona, co-fondatrice de Quintessenza, il y a une inspiration, une véritable histoire. Naît le souhait de parler des collections, de l'inspiration initiale jusqu'au produit fini, en développant le projet créatif à travers une histoire qui intéresse et émotionne.

La recherche constante de nouvelles tendances nous met en relation avec le design d'auteur: c'est ainsi qu'a commencé la première collaboration avec la coloriste et décoratrice d'intérieur Tekla Evelina Severin. Cette contamination apporte une valeur ajoutée: le raffinement de Quintessenza Ceramiche demeure mais avec un esprit plus métaphysique.

10 **FÄRGBLOCK**

■ 5X15CM
2"X6"

28 **MAREA**

● 7,5X30CM
3"X11,8"

44 **MINIMA8.6**

■ 17X15CM
6.7"X5.9" 

58 **PIGMENTO10**

■ 10X10CM
4"X4" 

74 **PIGMENTO**

■ 6X37CM
2.4"X14.5" 

88 **MODULO**

■ 5,6X23,2CM
2.2"X9.1" 

100 **OLTRE**

■ 18,6X18,6CM
7.3"X7.3" 

118 **CONFETTI**

■ 18,6X18,6CM
7.3"X7.3" 

132 **TINTE**

● 5X25CM
2"X10" 



148 **3LATI**

● 13,2X11,4CM
5.2"X4.5" 

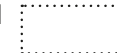
160 **RIQUADRI**

● 13,2X26,6CM
5.2"X10.5" 

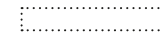
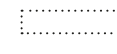
170 **GENESI**

● 13,2X40CM
5.2"X15.8" 
6,5X40CM
2.5"X15.8" 
6,5X26,6CM
2.5"X10.5" 
6,5X13,2CM
2.5"X5.2" 
13,2X13,2CM
5.2"X5.2" 

180 **CROMIA26**

● 6,5X26,6CM
2.5"X10.5" 

190 **SFUMATURE**

● 6,5X33CM
2.5"X13" 

202 **PORTICCIOLO**

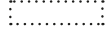
● 5X25CM
2"X10" 

210 **ALCHIMIA**

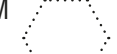
■ 26,6X23CM
10.5"X9" 

220 **SUPERFICI20**

■ 20X20CM
8"X8" 

INFORMAZIONI
INFORMATION

233 **PESI E IMBALLI**
PACKING

234 **CARATTERISTICHE TECNICHE**
TECHNICAL FEATURES
CARACTÉRISTIQUES TECHNIQUES

239 **CONDIZIONI GENERALI DI VENDITA**
GENERAL TERMS AND CONDITIONS OF SALE
CONDITIONS GÉNÉRALES DE VENTE

242 **ISTRUZIONI DI POSA E MANTENIMENTO**
INSTALLATION AND MAINTENANCE GUIDE
INSTRUCTIONS DE POSE ET D'ENTRETIEN

248 **CERTIFICAZIONI E SOSTENIBILITÀ AMBIENTALE**
ENVIRONMENTAL SUSTAINABILITY AND CERTIFICATION
CERTIFICATIONS ET DURABILITÉ ENVIRONNEMENTALE

252 **CREDITS**

■ GRES PORCELLANATO
PORCELAIN STONEWARE

● RIVESTIMENTO IN PASTA BIANCA
WHITE BODY WELL TILES

FÄRGBLOCK

Teklan edition x QC

Gres porcellanato
Porcelain stoneware

Monocromatico
Monochromatic
V1

Lucido/Matt
Glossy/Matt

Riciclato
Recycled
47%

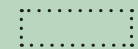

5x15CM
2"x6"

8MM



Scopri di più
su Färgblokk
Discover more
about Färgblokk

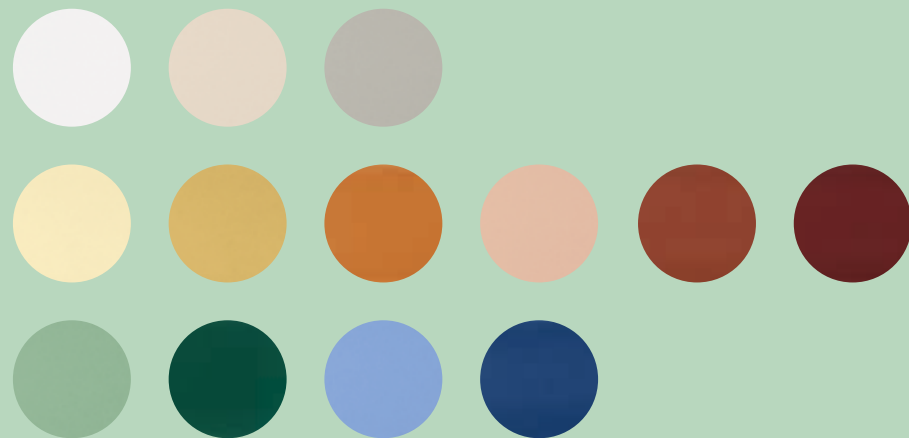

Färgblokk - in inglese color block - è la collezione ceramica sviluppata in collaborazione con l'interior designer e colorist Tekla Evelina Severin @teklan. Il valore aggiunto della collezione è proprio il formato, scelto in quanto la misura dei due lati consente di creare pattern modulari. Realizzata nella finitura lucida poi arricchita con la nuova finitura matt, Färgblokk, è capace di unire alle performance tecniche del grés, un impatto estetico forte e contemporaneo. Una collezione versatile che può essere inserita sia in contesti residenziali che commerciali, per applicazioni indoor e outdoor.



färgblokk borgogna matt, senape matt, arancio matt, cannella matt, menta matt, smeraldo matt, oceano matt

Färgblock - colour block in English - is our ceramic collection developed in collaboration with the designer and colorist Tekla Evelina Severin @teklan. The collection's added value, in fact, is its format, which has been chosen as the lengths of its sides allow modular patterns to be created. Originally released in a gloss finish and later enhanced with a new matt finish, Färgblock combines the technical performance of stoneware with a powerful and contemporary style. It is a versatile collection that can be inserted in indoor and outdoor.

Färgblock - en anglais color block - est la collection céramique développée en collaboration avec l'architecte d'intérieur et coloriste Tekla Evelina Severin @teklan. La valeur ajoutée de la collection est précisément le format, choisi car la taille des deux faces permet de créer des motifs modulables. Fabriqué dans la finition brillante et mat, Färgblock est capable de combiner les performances techniques du grès cérame avec un impact esthétique fort et contemporain. Une collection polyvalente qui peut être insérée.

färgblock senape lucido, champagne lucido, cannella lucido, borgogna lucido, menta lucido, smeraldo lucido, cielo lucido, arancio lucido, senape matt, champagne matt, borgogna matt, menta matt, cielo matt, arancio matt, rosa matt

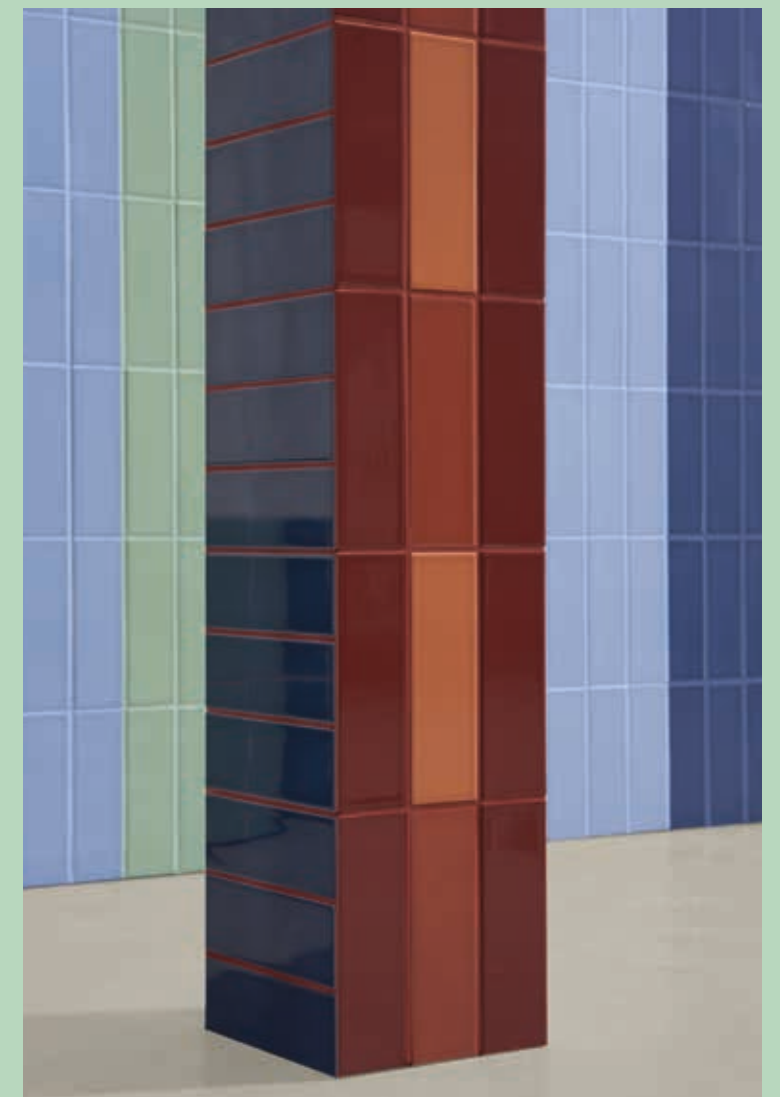

färgblock oceano lucido, cielo lucido, arancio lucido, borgogna lucido, menta lucido, cannella lucido



färgblock smeraldo lucido, sabbia lucido, cenere lucido, bianco lucido, champagne lucido
confetti bianco.beige



färgblock bianco matt, senape matt, borgogna matt,
champagne matt, oceano matt

färgblock smeraldo lucido, menta lucido,
cielo lucido, oceano lucido, arancio lucido,
oltre9 cotto.blu



färgblock borgogna matt, senape matt, sabbia matt, cenere matt, cielo lucido

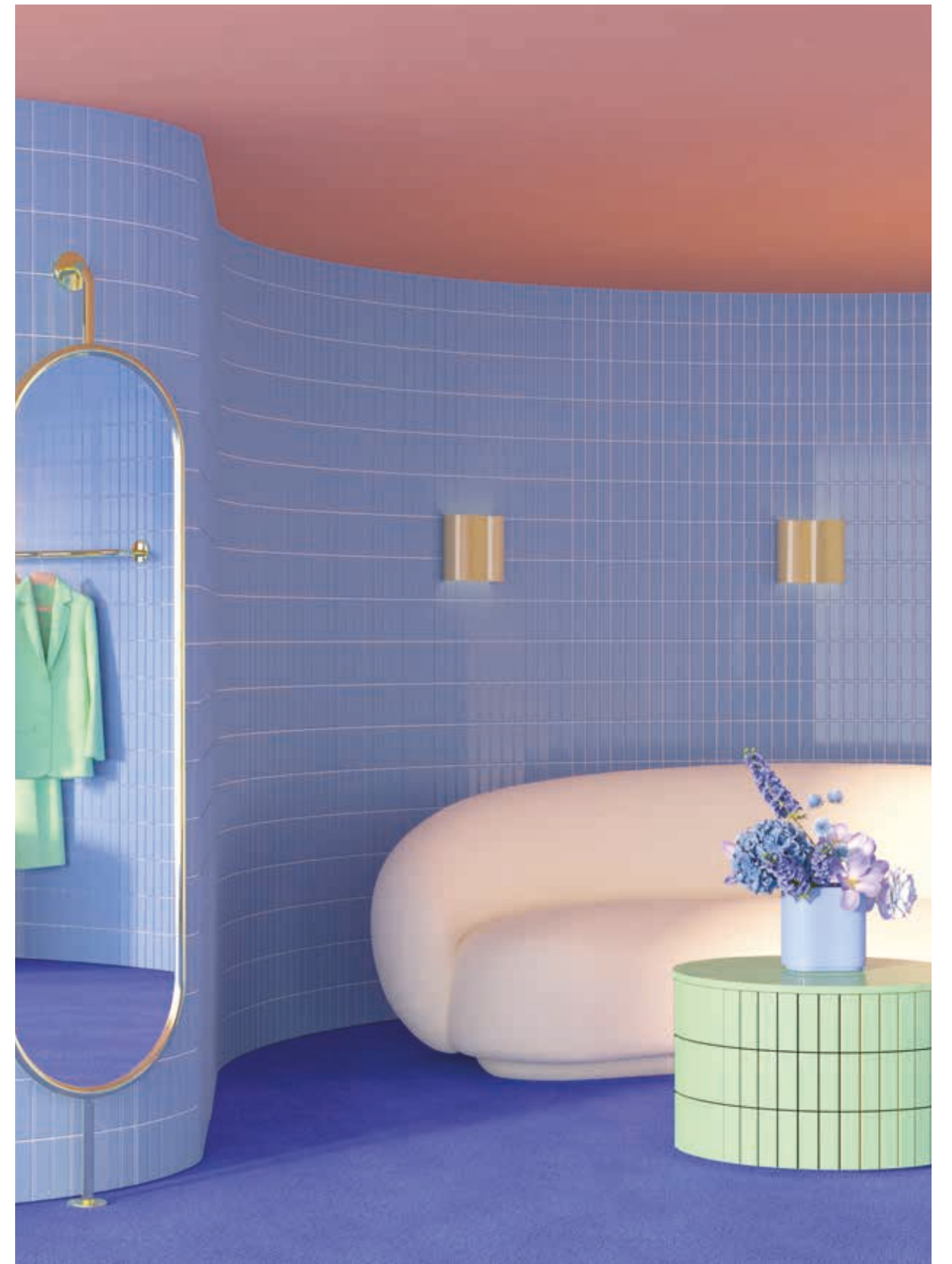

färgblock menta lucido, cielo lucido

färgblock cielo matt, cielo lucido, cannella matt,
cipria matt, arancio matt, borgogna matt



färgblocc menta lucido, smeraldo lucido, arancio lucido, cipria lucido,
bianco lucido, cannella lucido

FÄRGBLOCK

Teklan edition x QC

5x15cm
2x6"
8MM

Gres porcellanato
Porcelain stoneware

Monocromatico
Monochromatic

Lucido/Matt
Glossy/Matt

Materiale riciclato
Recycled Content

47%

V1

CIPRIA LUCIDO FGB108L ■ 09



MENTA LUCIDO FGB106L ■ 09

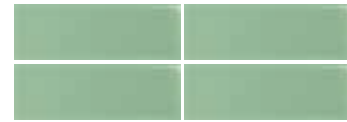

CIPRIA MATT FGB121M ■ 09

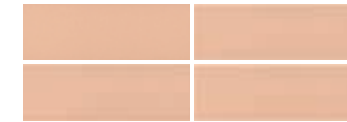

MENTA MATT FGB119M ■ 09

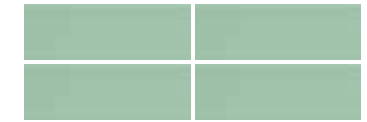

ARANCIO LUCIDO FGB109L ■ 09



SMERALDO LUCIDO FGB107L ■ 10



ARANCIO MATT FGB122M ■ 09

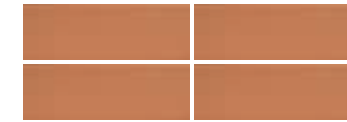

SMERALDO MATT FGB120M ■ 10



CANNELLA LUCIDO FGB110L ■ 10



CIELO LUCIDO FGB104L ■ 09



CANNELLA MATT FGB123M ■ 10



CIELO MATT FGB117M ■ 09

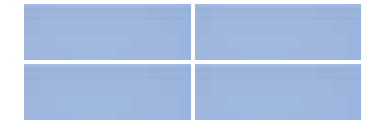

BORGOGNA LUCIDO FGB111L ■ 10



OCEANO LUCIDO FGB105L ■ 10



BORGOGNA MATT FGB124M ■ 10



OCEANO MATT FGB118M ■ 10

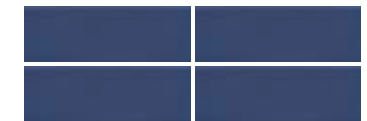

CHAMPAGNE LUCIDO FGB112L ■ 09

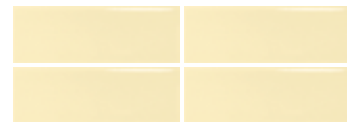

CENERE LUCIDO FGB103L ■ 09



CHAMPAGNE MATT FGB125M ■ 09

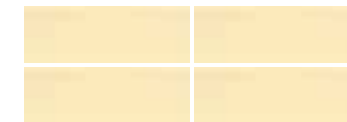

CENERE MATT FGB116M ■ 09



SENAPE LUCIDO FGB113L ■ 09



SABBIA LUCIDO FGB102L ■ 09



SENAPE MATT FGB126M ■ 09



SABBIA MATT FGB115M ■ 09

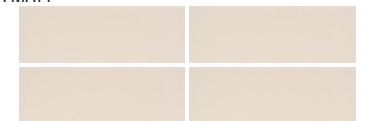

BIANCO LUCIDO FGB101L ■ 09

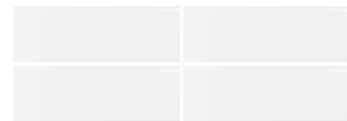

BIANCO MATT FGB114M ■ 09

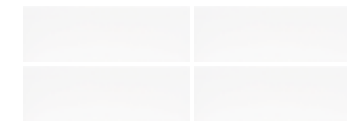

Imballi | Packing

ARTICOLO ITEM	FORMATO SIZE	SCATOLA BOX			PALLET PALLET			
		PZ	MQ	KG	BOX	PZ	MQ	KG
Färgbloc lucido	5x15cm 2"x6"	80	0,6	10,90	84	6720	50,4	936
Färgbloc matt	5x15cm 2"x6"	80	0,6	10,90	84	6720	50,4	936

Dimensioni | Sizing

Piastrelle non rettificate soggette a lievi differenze di calibro.
 Non-rectified tiles subject to slight differences in calibre.
 Carreaux non rectifiés pouvant comporter de légères différences de calibre.

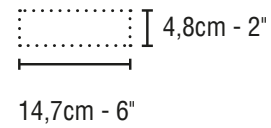

Fuga | Joint

Fuga minima 2mm. Compensare differenze di calibro con la fuga.
 Minimum 2mm joint. Compensate for differences in caliber with the joint.
 Joint d'au moins 2mm. Compenser les différences de calibre avec le joint.

Posa modulare | Modular installation

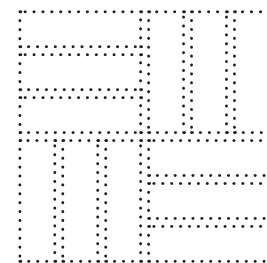

Colori NCS | NCS Colours

Bianco	NCS S 0500-N
Sabbia	NCS S 1505-Y40R
Cenere	NCS S 3502-R
Champagne	NCS S1515-Y10R
Senape	NCS S 3030-Y10R
Borgogna	NCS S 5030-R
Cannella	NCS S 4040-Y80R
Arancio	NCS S 3040-Y60R
Cipria	NCS S 2020-Y60R
Menta	NCS S 2020-G10Y
Smeraldo	NCS S 6030-G
Cielo	NCS S 2030-R80B
Oceano	NCS S 6020-R70B

QC MORE +

Scansiona il QR per accedere a info aggiuntive su:
 - Colori NCS | Stucchi
 - Schemi di posa
 - Caratteristiche tecniche



Scan the QR code to access additional information on:
 - Colour NCS | Grouts
 - Laying patterns
 - Technical characteristics

Scanne le QR code pour accéder aux informations successives sur:
 - Couleurs NCS | Joints
 - Schémas d'installation
 - Les caractéristiques techniques

Abbinamenti consigliati | Suggested combinations

Confetti, Oltre, Minima8.6, Alchimia, Superfici20, Pigmento



färgbloc cannella matt, cipria matt, arancio matt, borgogna matt

MAREA

Rivestimento in pasta bianca
White body wall tiles

 Monocromatico
Monochromatic
V1

 Matt/Lucido
Matt/Gloss

 Materiale riciclato
Recycled Content
61%



7,5x30CM
3"x11.8"

 8/13MM



Scopri di più
su Marea
Discover more
about Marea

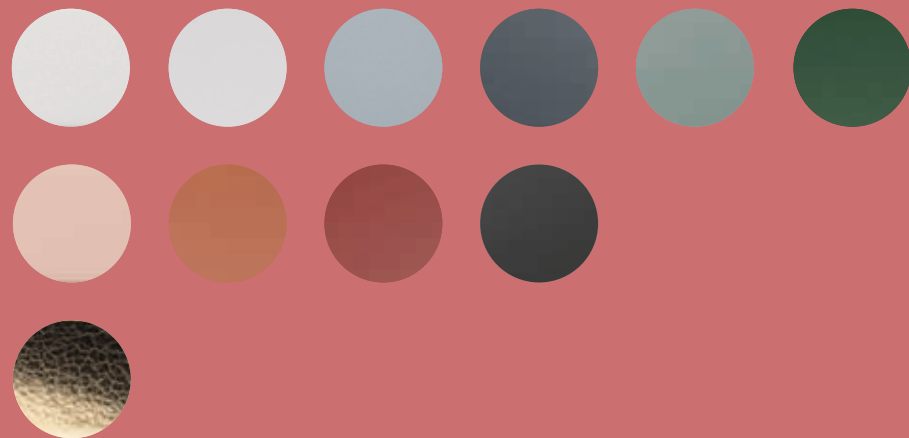

È lungo l'incerto confine che separa il cielo dall'acqua, sfumato dalla danza delle onde che nasce Marea. Una collezione con una tridimensionalità scultorea e rigorosa, minimalista e vibrante di energia, ispirata dai ciclici movimenti del mare influenzati dalla luna. Marea è una collezione ceramica in pasta bianca smaltata, dal formato 7,5x30cm e disponibile in 3 strutture: la base liscia e la struttura convessa nella finitura matt e la struttura concava nella finitura lucida.

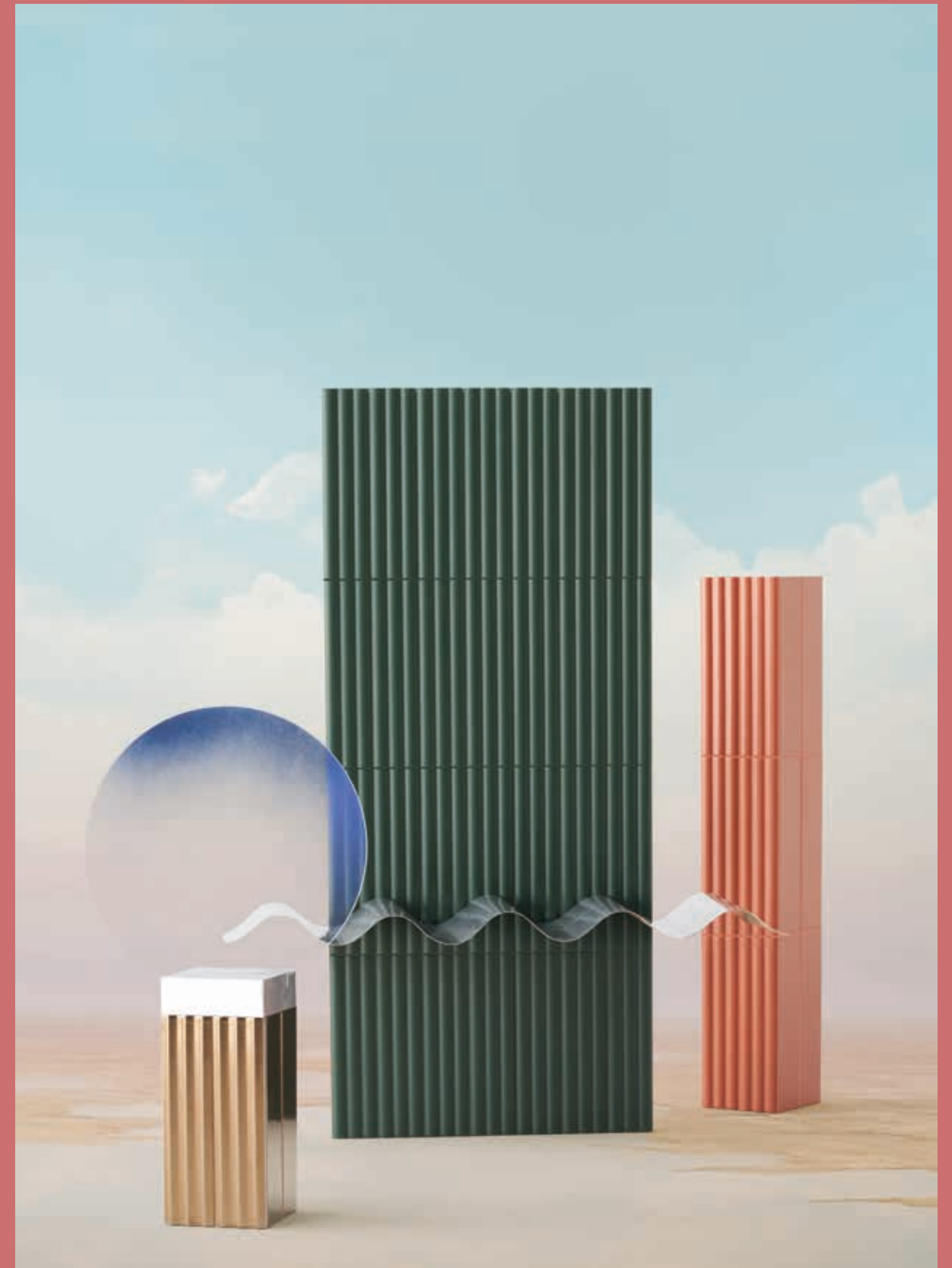

marea terra matt, oro, alta-marea terra matt, smeraldo matt, bassa-marea oro



It is along the uncertain border that separates the sky from the water, blurred by the dance of the waves that Marea is born. A collection with a sculptural and rigorous three-dimensionality, minimalist and vibrant with energy, inspired by the cyclical movements of the sea influenced by the moon. Marea is a glazed white body ceramic collection, in the 7.5x30cm format and available in 3 structures: the smooth base and the convex structure in the matt finish and the concave structure in the glossy finish.

C'est le long de la frontière incertaine qui sépare le ciel de l'eau, brouillée par la danse des vagues, que naît Marea. Une collection à la tridimensionnalité sculpturale et rigoureuse, minimaliste et vibrante d'énergie, inspirée par les mouvements cycliques de la mer influencés par la lune. Marea est une collection de céramique émaillée en pâte blanche, au format 7,5x30cm et disponible en 3 structures: la base lisse et la structure convexe en finition mate et la structure concave en finition brillante.



bassa-marea smeraldo lucido, **marea** smeraldo matt, base oltre verde

bassa-marea smeraldo lucido, **marea** smeraldo matt, **alta-marea** grigio matt, **jolly marea** grigio matt



marea oro, marea bianco matt, alta-marea terra matt, bassa marea terra lucido
oltre base bianco, nero



bassa-marea porpora lucido

alta-marea nero matt, bassa-marea grigio lucido
oltre9 nero.verde



bassa-marea nero lucido, salvia lucido, rosa lucido,
marea nero matt, **alta-marea** bianco matt, salvia matt, blu matt,
jolly marea verde lucido, rosa lucido, blu matt
 confetti bianco.petrolio



marea blu matt, **alta-marea** blu matt, porpora matt,
jolly marea blu matt,
 confetti nero.grigio



bassa-marea carta da zucchero lucido, grigio lucido, blu lucido,
marea carta da zucchero matt, blu matt, **alta-marea** grigio matt,
base oltre bianco

MAREA BIANCO MATT MAR101M ■ 26

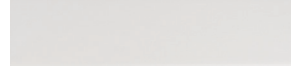

ALTA-MAREA BIANCO MATT MAR107M ■ 08



BASSA-MAREA BIANCO LUCIDO MAR113L ■ 08



MAREA ROSA MATT MAR102M ■ 26

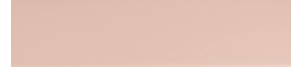

ALTA-MAREA ROSA MATT MAR108M ■ 08



BASSA-MAREA ROSA LUCIDO MAR114L ■ 08



MAREA SALVIA MATT MAR103M ■ 26

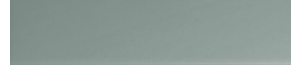

ALTA-MAREA SALVIA MATT MAR109M ■ 08



BASSA-MAREA SALVIA MATT MAR115L ■ 08



MAREA BLU MATT MAR104M ■ 26

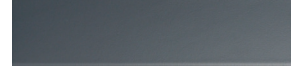

ALTA-MAREA BLU MATT MAR110M ■ 08

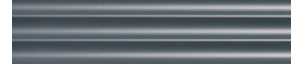

BASSA-MAREA BLU LUCIDO MAR116L ■ 08

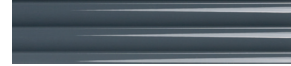

MAREA NERO MATT MAR105M ■ 26



ALTA-MAREA NERO MATT MAR111M ■ 08



BASSA-MAREA NERO LUCIDO MAR117L ■ 08



MAREA PORPORA MATT MAR106M ■ 26



ALTA-MAREA PORPORA MATT MAR112M ■ 08



BASSA-MAREA PORPORA LUCIDO MAR118L ■ 08



MAREA GRIGIO MATT MAR119M ■ 26

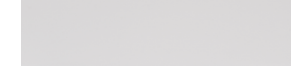

ALTA-MAREA GRIGIO MATT MAR124M ■ 08

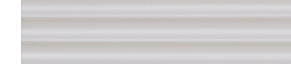

BASSA-MAREA GRIGIO LUCIDO MAR129L ■ 08



MAREA CARTA DA ZUCCHERO MATT MAR120M ■ 26

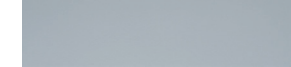

ALTA-MAREA CARTA DA ZUCCHERO MATT MAR125M ■ 08



BASSA-MAREA CARTA DA ZUCCHERO LUCIDO MAR130L ■ 08



MAREA SMERALDO MATT MAR122M ■ 26



ALTA-MAREA SMERALDO MATT MAR127M ■ 08



BASSA-MAREA SMERALDO LUCIDO MAR132L ■ 08



MAREA TERRA MATT MAR121M ■ 26



ALTA-MAREA TERRA MATT MAR126M ■ 08



BASSA-MAREA TERRA LUCIDO MAR131L ■ 08



MAREA ORO ■ MAR123L ■ 27



ALTA-MAREA ORO ■ MAR128L ■ 28



BASSA-MAREA ORO ■ MAR133L ■ 28



ATTENZIONE - PIASTRELLE CON COLORI METALLICI: ■
I colori metallizzati sono realizzati con smalti speciali che tendono ad avere un effetto crackle naturale e una bassa resistenza a prodotti acidi ed alcalini. Non utilizzare prodotti di pulizia aggressivi, come candeggina e ammoniaca. Consultare la guida per l'installazione e la manutenzione a pag. 242

WARNING - TILES WITH METALLIC COLORS: ■
Metallic colors are made with special glazes that tends to have a natural crackle effect and low resistance to acidic and alkaline cleaning products. Do not use aggressive cleaning products, such as bleach or ammonia. Check the installation and maintenance guide on page 244

ATTENTION - CARREAUX AVEC ÉMAUX MÉTALLIQUES: ■
les couleurs métallisées sont réalisées avec des émaux spéciaux qui tendent à avoir un effet craquelé naturel et une basse résistance aux produits acides et alcalins. Ne pas utiliser de produits agressifs pour le nettoyage comme l'eau de javel ou l'ammoniaque. Consultez les conseils d'instructions de pose et d'entretien page 246

Imballi | Packing

ARTICOLO ITEM	FORMATO SIZE	SCATOLA BOX			PALLET PALLET			
		PZ	MQ	KG	BOX	PZ	MQ	KG
Marea	7,5x30cm 3"x11.8"	24	0,54	7,90	96	2.304	51,84	778,40
Alta-marea	7,5x30cm 3"x11.8"	20	0,45	8,05	96	1.920	43,20	792,80
Bassa-marea	7,5x30cm 3"x11.8"	22	0,50	8,00	96	2.112	48,00	788,00
Jolly	1,5x30cm 0.5"x11.8"	6	/	0,40	/	/	/	/

Pezzi speciali | Special pieces

 jolly 1,2x30cm 0.5"x11.8"	bianco matt	MAR501M ●07	bianco lucido	MAR507L ●07
	rosa matt	MAR502M ●07	rosa lucido	MAR508L ●07
	salvia matt	MAR503M ●07	salvia lucido	MAR509L ●07
	blu matt	MAR504M ●07	blu lucido	MAR510L ●07
	nero matt	MAR505M ●07	nero lucido	MAR511L ●07
	porpora matt	MAR506M ●07	porpora lucido	MAR512L ●07
	grigio matt	MAR518M ●07	grigio lucido	MAR513L ●07
	carta da zucchero matt	MAR519M ●07	carta da zucchero lucido	MAR514L ●07
	terra matt	MAR520M ●07	terra lucido	MAR515L ●07
	smeraldo matt	MAR521M ●07	smeraldo lucido	MAR516L ●07

Dimensioni | Sizing

Piastrelle non rettificate | Non-rectified tiles
 Carreaux non rectifiés

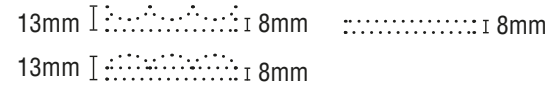
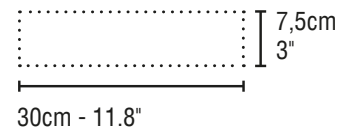

Colori NCS | NCS Colours

Bianco	NCS S 0500-N
Rosa	NCS S 2010-Y70R
Porpora	NCS S 5040-R
Salvia	NCS S 4010-B90G
Blu	NCS S 7010-R90B
Nero	NCS S 8500-N
Grigio	NCS S 2002-R
Terra	NCS S 3050-Y70R
Smeraldo	NCS S 7020-G10Y
Carta da zucchero	NCS S 3010-B

Fuga | Joint

Fuga minima 2mm | Minimum joint 2mm
 Joint d'au moins 2mm

QC MORE +

Scansiona il QR per accedere a info aggiuntive su:
 - Colori NCS | Stucchi
 - Schemi di posa
 - Caratteristiche tecniche



Scan the QR code to access additional information on:
 - Colour NCS | Grouts
 - Laying patterns
 - Technical characteristics

Scanne le QR code pour accéder aux informations successives sur:
 - Couleurs NCS | Joints
 - Schémas d'installation
 - Les caractéristiques techniques

Abbinamenti consigliati | Suggested combinations

Confetti, Pigmento, Pigmento10, Minima8.6, Alchimia, Superfici20, Oltre



bassa-marea carta da zucchero lucido, grigio lucido, blu lucido,
 marea carta da zucchero matt, blu matt, alta-marea grigio matt,
 base oltre bianco

MINIMA8.6

Gres porcellanato
Porcelain stoneware

Monocromatico\Texture
Monochromatic\Texture
V1/V4

Matt
Matt

Materiale riciclato
Recycled Content
39%



17x15cm
6.7"x5.9"

9MM



Scopri di più
su Minima8.6
Discover more
about Minima8.6

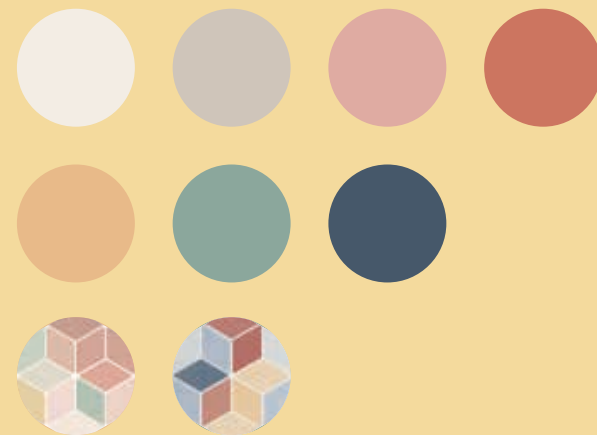

La collezione Minima8.6 in gres porcellanato si caratterizza per il formato esagonale dall'anima retrò ma rivisitata in chiave contemporanea. È disponibile nel formato 17x15cm e si sviluppa in 7 colori di tendenza più due pattern con motivo geometrico dal forte impatto visivo. La superficie è leggermente strutturata per dare maggiore movimento alle pareti. È un'ottima soluzione per dare brio a pavimenti e rivestimenti: influenze grafiche e materiche che permettono di creare composizioni che valorizzano con gusto ogni stile ed ogni ambiente.



minima8.6 multi color2, ocra, blu, cotto, rosa



The Minima8.6 porcelain stoneware collection stands out for its hexagonal shape and retro soul rendered in a contemporary style. It is available in a 17x15cm format and 7 on-trend colours plus two patterns with a visually striking geometrical motif. The surface is slightly textured to make walls come alive. It is an excellent solution for adding verve to floors and walls thanks to its textures and graphic influences that allow you to create compositions which will tastefully enhance any style and any room.

La collection Minima8.6 en grès cérame se caractérise par le format hexagonal à l'âme rétro mais revisité dans un style plus contemporain. Cette collection est disponible en format 17x15cm et se décline en 7 coloris tendance ainsi que deux décors au motif géométrique à fort impact visuel. La surface est légèrement structurée pour donner plus de mouvement aux différents types de pose. C'est une excellente solution pour donner de la vivacité tant aux sols qu'aux murs: des influences graphiques et de matériaux naturels qui permettent de créer des compositions mettant en valeur avec goût chaque style et chaque projet.



minima8.6 multi color1,
cotto, rosa

minima8.6 cotto, rosa



minima8.6 ocra, rosa, salvia, cotto, multi color1

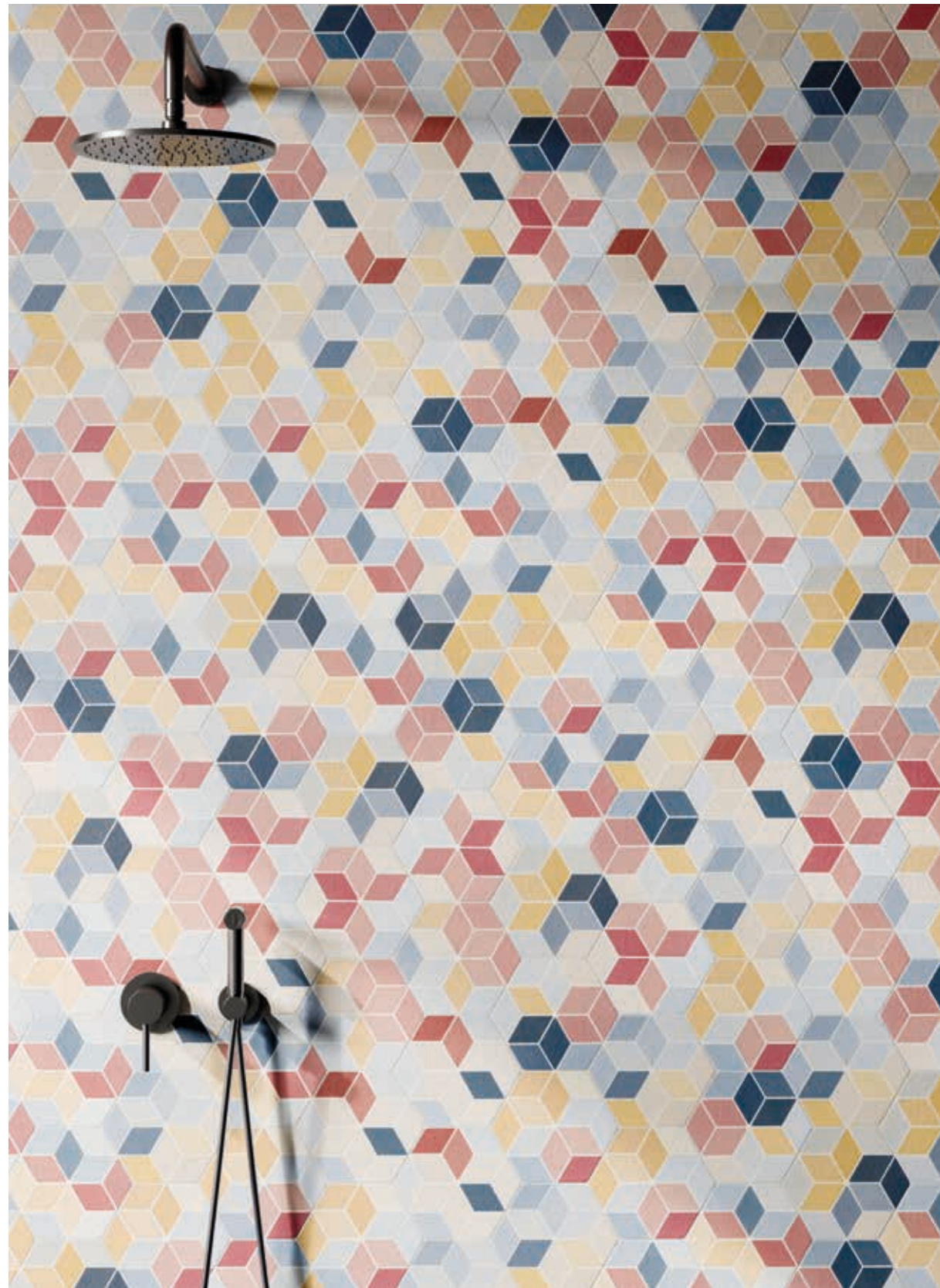

minima8.6 multi color2



minima8.6 bianco, greige, cotto, blu, multi color2



minima8.6 bianco, multi color2

MINIMA8.6



17x15cm
6.7"x5.9"

9MM

Gres porcellanato
Porcelain stoneware

Monocromatico\Texture
Monochromatic\Texture
V1/V4

Matt
Matt

Materiale riciclato
Recycled Content
39%

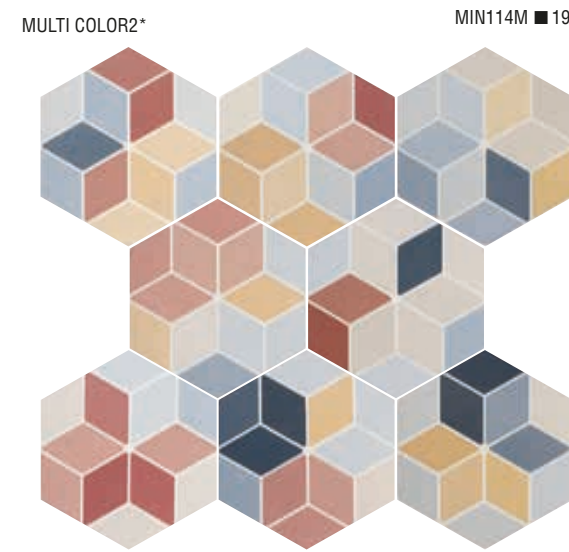
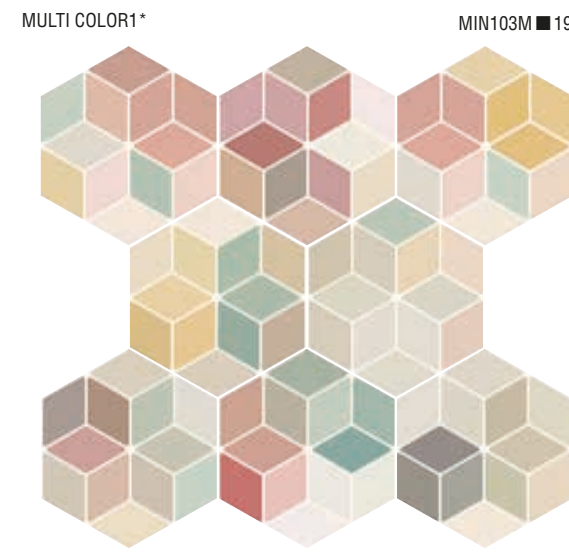
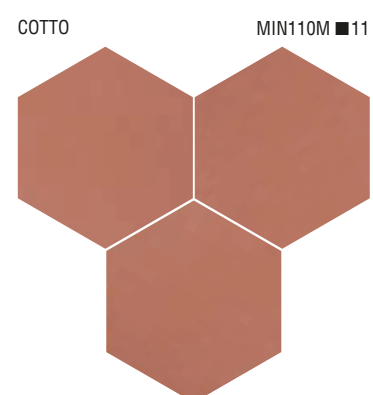
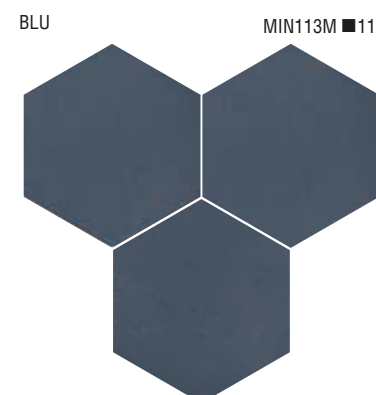
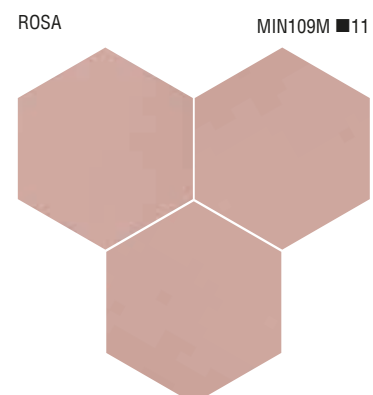
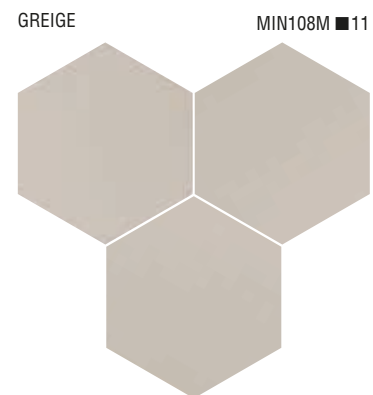
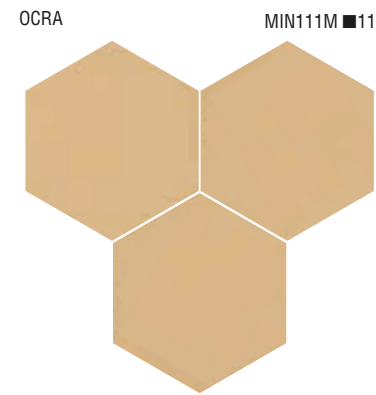
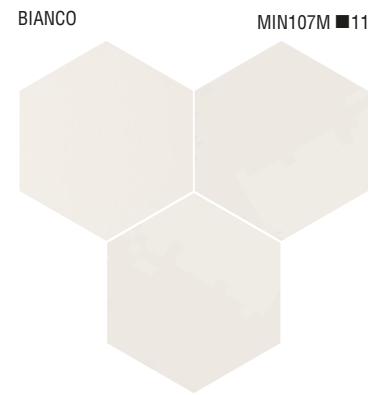

Stonalizzato
Shade variation

V1 bianco, ocra, greige, salvia,
rosa, blu, cotto

V4 multi color1, multi color2

* Articoli composti da diverse grafiche confezionate casualmente all'interno della stessa scatola.

* Items made up of different patterns, randomly packed in the same box.

* Articles composés de différents patrons et mélangés à l'intérieur de chaque boîte.

Imballi | Packing

ARTICOLO ITEM	FORMATO SIZE	SCATOLA BOX			PALLET PALLET			
		PZ	MQ	KG	BOX	PZ	MQ	KG
Minima8.6	17x15cm 6.7"x5.9"	29	0,57	11,25	80	2.320	45,60	920
Multicolor	17x15cm 6.7"x5.9"	29	0,57	11,25	80	2.320	45,60	920

Dimensioni | Sizing

Piastrelle non rettificata soggette a lievi differenze di calibro.
 Non-rectified tiles subject to slight differences in calibre.
 Carreaux non rectifiés pouvant comporter de légères différences de calibre.

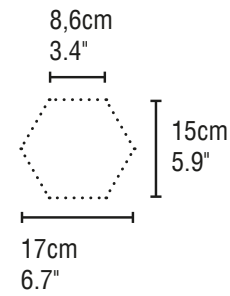

Fuga | Joint

Fuga minima 1mm. Compensare differenze di calibro con la fuga.
 Minimum 1mm joint. Compensate for differences in caliber with the joint.
 Joint d'au moins 1mm. Compenser les différences de calibre avec le joint.

QC MORE +

Scansiona il QR per accedere a info aggiuntive su:
 - Colori NCS | Stucchi
 - Caratteristiche tecniche



Scan the QR code to access additional information on:
 - Colour NCS | Grouts
 - Technical characteristics

Scanne le QR code pour accéder aux informations successives sur :
 - Couleurs NCS | Joints
 - Les caractéristiques techniques

Colori NCS | NCS Colours

Bianco	NCS S 1002-Y
Rosa	NCS S 3020-Y80R
Greige	NCS S 3005-Y20R
Salvia	NCS S 5010-G10Y
Cotto	NCS S 4030-Y80R
Blu	NCS S 7010-R90B
Ocra	NCS S 2030-Y20R

Abbinamenti consigliati | Suggested combinations

Färgblock, Marea, Tinte, 3Lati, Riquadri, Cromia26, Oltre, Genesi, Pigmento10, Pigmento, Modulo, Porticciolo

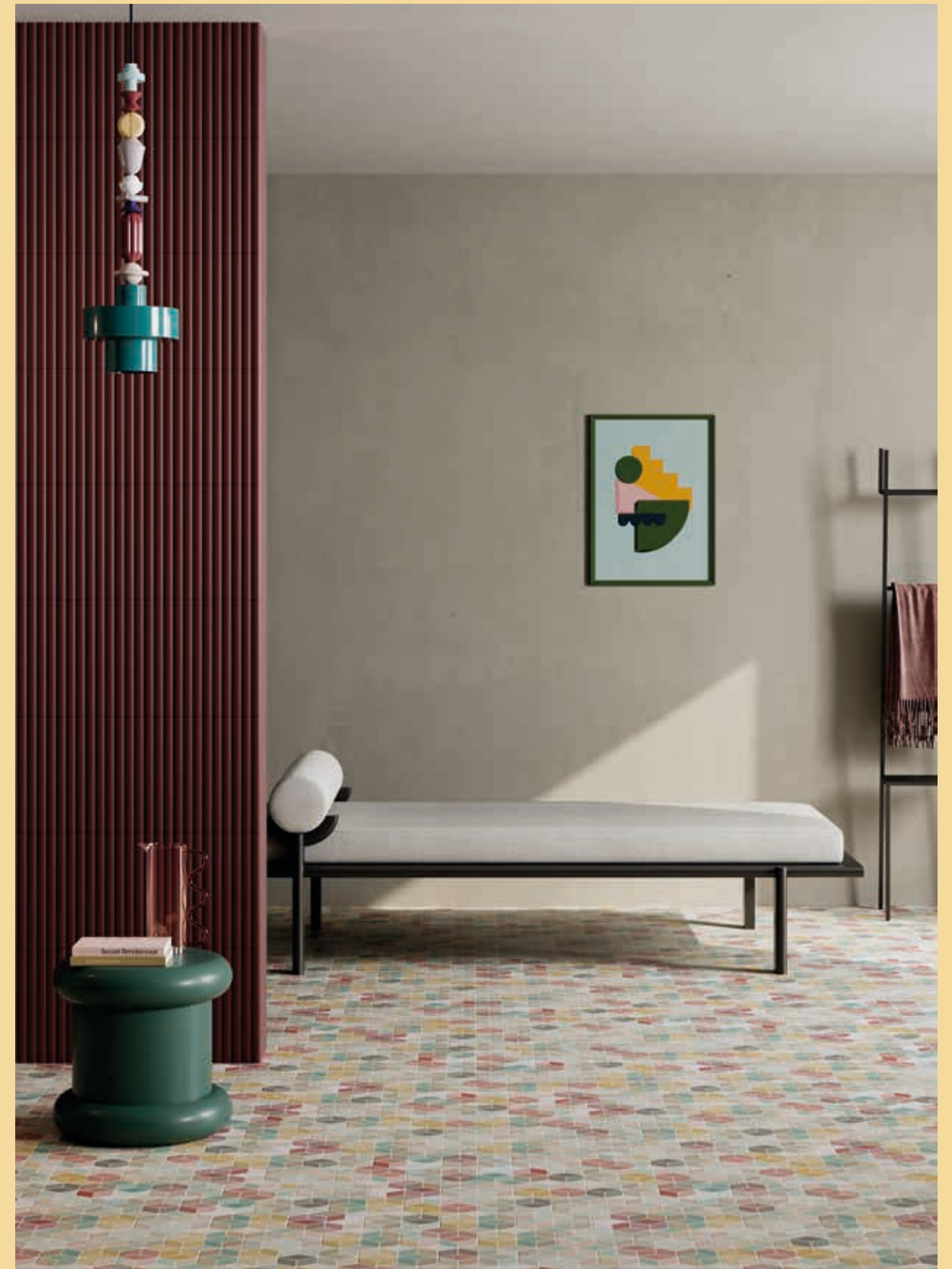

minima8.6 multi color1, alta-marea porpora matt, jolly marea porpora matt

PIGMENTO10

Gres porcellanato
Porcelain stoneware

Stonalizzato
Shade variation
V3

Matt
Matt

Materiale riciclato
Recycled Content
43%

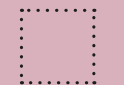

10x10cm
4"x4"

8MM



Scopri di più
su Pigmento10
Discover more
about Pigmento10

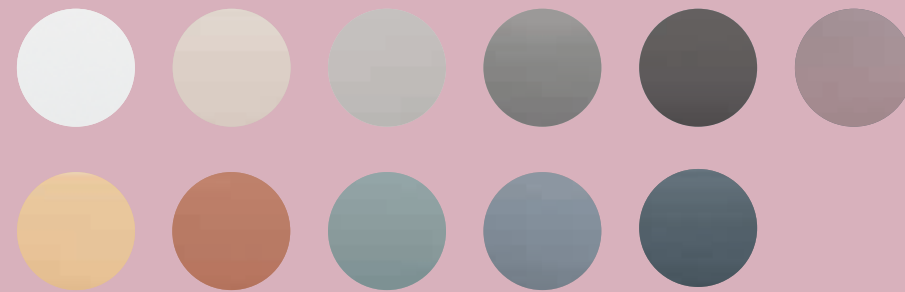

Pigmento10 è la nuova collezione in gres porcellanato che prende spunto dalla collezione Pigmento 6x37cm ma riproposta nel formato 10x10cm. Una serie dedicata al colore che diventa strumento e protagonista progettuale. La palette è composta da 11 tinte che si muovono tra colori più neutri e versatili come beige, fango, bianco, grigio e nero, e accostamenti più vivaci come ocra, terra, verde, azzurro, blu e malva. La peculiarità stilistica di questa collezione è la stonalizzazione: il delicato andamento della sfumatura sulla superficie opaca e la ricchezza delle nuances generano effetti cromaticisofisticati.



pigmento10 terra, azzurro, ocra



Pigmento10 is a new porcelain stoneware collection inspired by the Pigmento 6x37cm collection, restyled in a 10x10cm format. It is a series dedicated to colour as both a tool and a front-line player in design. Its colour palette consists of 11 different shades that range from more neutral and versatile tones such as beige, mud, white, grey and black, to vibrant combinations like ochre, earth, green, light blue, blue and mauve. What makes this collection particularly unique is its tone variations. As the delicate changes in shade on these matt surfaces and the richness of their nuances generate highly sophisticated colour effects.

Pigmento10 est la nouvelle collection en grès cérame qui s'inspire de la collection Pigmento 6x37cm mais proposée en format 10x10cm. Une série dédiée à la couleur qui devient un outil de conception et un protagoniste. La palette est composée de 11 nuances qui oscillent entre des couleurs plus neutres et polyvalentes comme le beige, le gris taupe, le blanc, le gris et le noir, et des combinaisons plus vives comme l'ocre, le terre, le vert, le bleu clair, le bleu et le mauve. La particularité stylistique de cette collection est la variation des nuances: la délicate progression de la teinte sur la surface mate et la richesse des nuances génèrent des effets chromatiques sophistiqués.

pigmento10 malva, terra, beige, blu, ocre
pigmento 6x37 blu



pigmento10 malva, terra, beige, blu, ocre
pigmento 6x37 blu



pigmento10 nero, azzurro, bianco



pigmento10 malva, blu, azzurro, grigio

pigmento10 azzurro, grigio



pigmento10 ocra, verde, terra
pigmento 6x37 beige



pigmento10 fango
pigmento 6x37 terra



pigmento10 fango, bianco
pigmento 6x37 terra

PIGMENTO10

10x10cm
4"x4"

8MM

Gres porcellanato
Porcelain stoneware

Stonalizzato
Shade variation
V3

Matt
Matt

Materiale riciclato
Recycled Content
43%

BIANCO PGM112M ■ 07

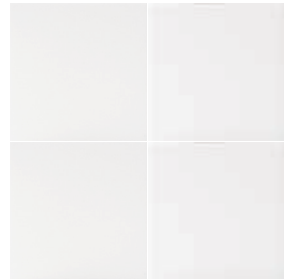

AZZURRO PGM117M ■ 07

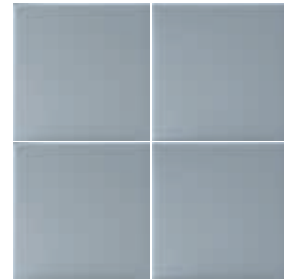

BEIGE PGM121M ■ 07



VERDE PGM118M ■ 07

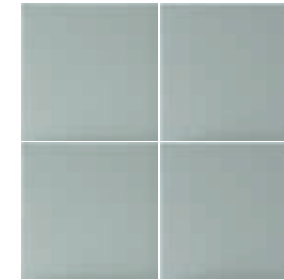

GRIGIO PGM113M ■ 07

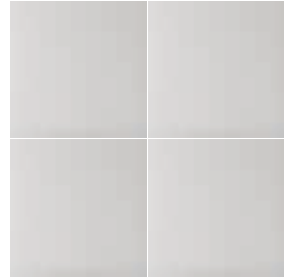

BLU PGM122M ■ 07

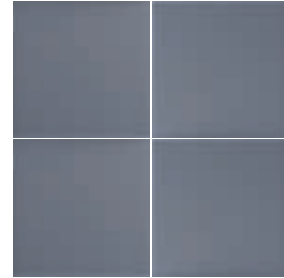

OCRA PGM120M ■ 07

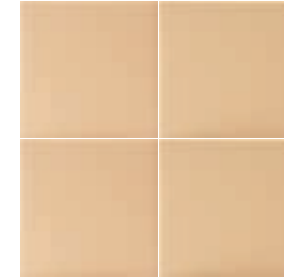

MALVA PGM116M ■ 07

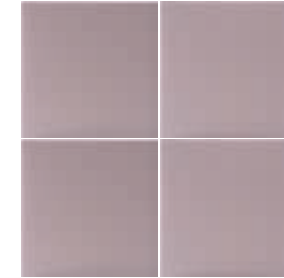

FANGO PGM114M ■ 07

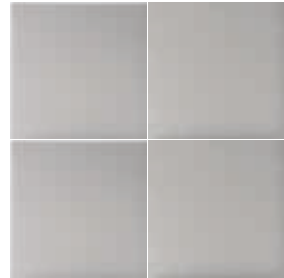

NERO PGM115M ■ 07

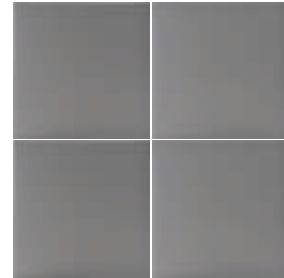

TERRA PGM119M ■ 07

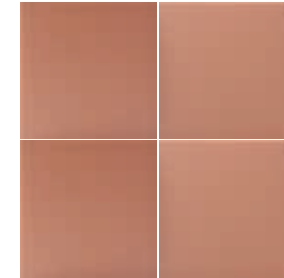

Imballi | Packing

ARTICOLO ITEM	FORMATO SIZE	SCATOLA BOX			PALLET PALLET			
		PZ	MQ	KG	BOX	PZ	MQ	KG
Pigmento10	10x10cm 4"x4"	50	0,5	9,50	90	4.500	45	875

Dimensioni | Sizing

Piastrelle non rettificate soggette a lievi differenze di calibro.
 Non-rectified tiles subject to slight differences in calibre.
 Carreaux non rectifiés pouvant comporter de légères différences de calibre.

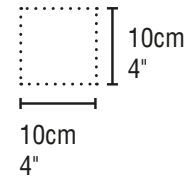

Fuga | Joint

Fuga minima 2mm. Compensare differenze di calibro con la fuga.
 Minimum 2mm joint. Compensate for differences in caliber with the joint.
 Joint d'au moins 2mm. Compenser les différences de calibre avec le joint.

QC MORE +

Scansiona il QR per accedere a info aggiuntive su:
 - Colori NCS | Stucchi
 - Caratteristiche tecniche



Scan the QR code to access additional information on:
 - Colour NCS | Grouts
 - Technical characteristics

Scanne le QR code pour accéder aux informations successives sur :
 - Couleurs NCS | Joints
 - Les caractéristiques techniques

Colori NCS | NCS Colours

Bianco	NCS S 1002-G50Y
Grigio	NCS S 2500-N
Fango	NCS S 4500-N
Nero	NCS S 7000-N
Blu	NCS S 6010-R90B
Terra	NCS S 4030-Y60R
Ocra	NCS S 2030-Y20R
Beige	NCS S 2005-Y30R
Azzurro	NCS S 4010-R90B
Verde	NCS S 4010-B70G
Malva	NCS S 4010-R10B

Abbinamenti consigliati | Suggested combinations

Färgblock, Tinte, 3Lati, Riquadri, Cromia26, Oltre, Pigmento, Confetti, Minima8.6, Alchimia, Marea, Sfumature, Genesi

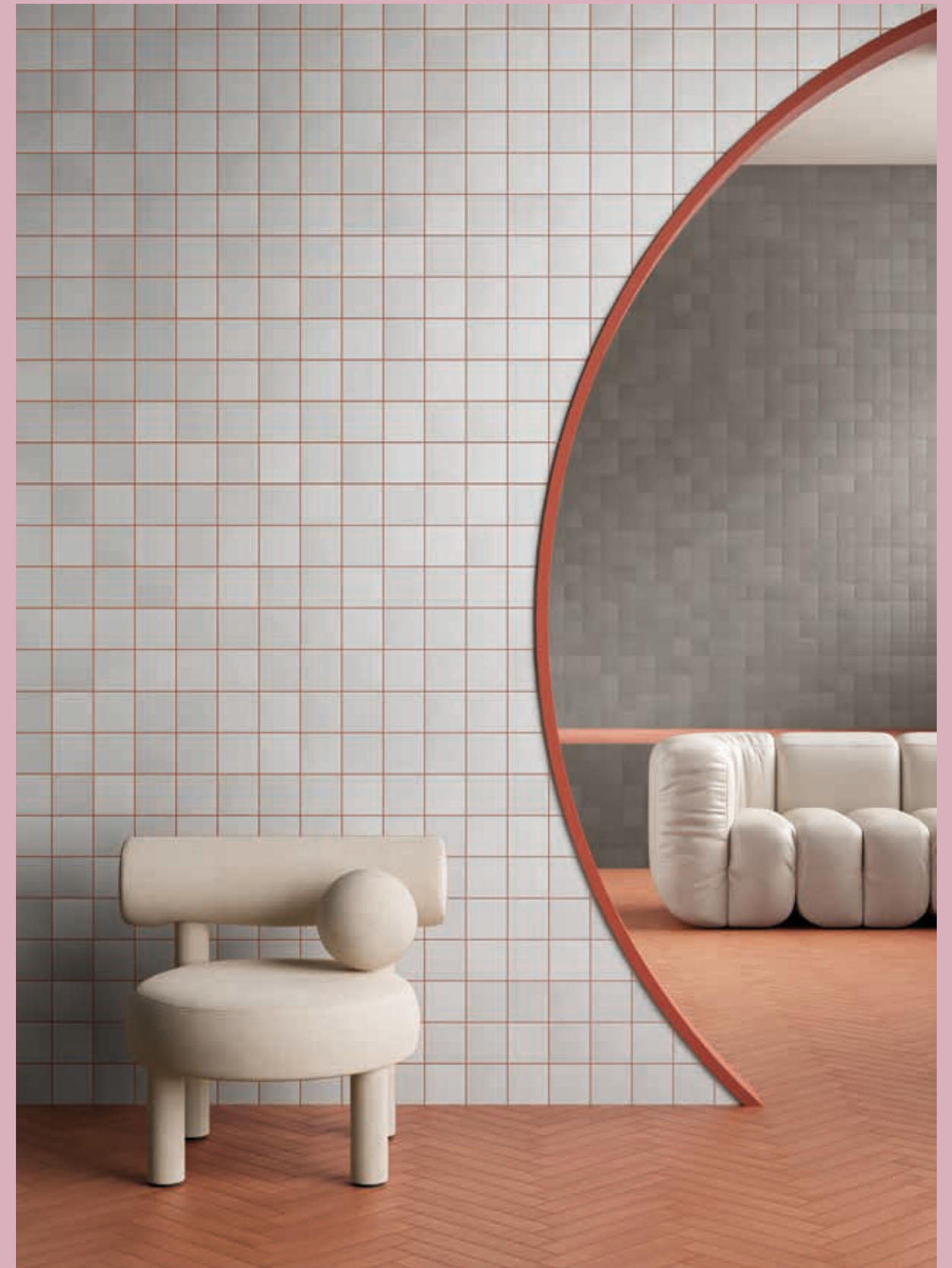

pigmento10 fango, bianco
 pigmento 6x37 terra

PIGMENTO

Gres porcellanato
Porcelain stoneware

Stonalizzato
Shade variation
V3

Matt
Matt

Materiale riciclato
Recycled Content
43%



6x37cm
2.4"x14.5"

8MM



Scopri di più
su Pigmento
Discover more
about Pigmento

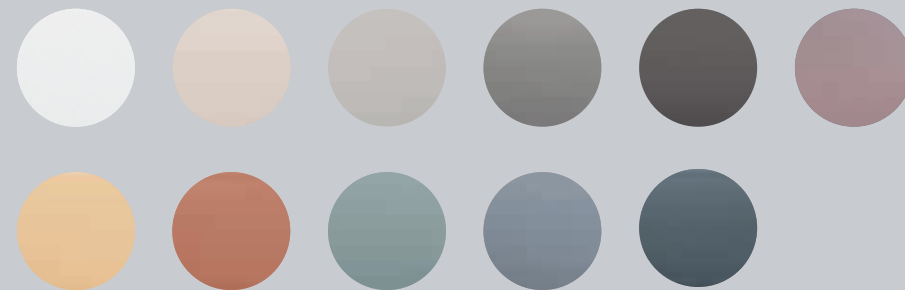

Il delicato andamento delle superfici opaca e la ricchezza delle nuances cromatiche generano oltre 60 toni diversi per ciascuno degli 11 colori della collezione. Le infinite combinazioni di colore di Pigmento rappresentano una sfida per la creatività, mentre la sua decisa stonalizzazione fa di ogni campitura monocroma un mosaico di sfumature. La collezione è arricchita dal decoro Lustrò, che stende sul colore un velo lucido, per innesti di luce sparsi o disegni tono su tono.



pigmento terra, fango, verde



The delicate effect of its matt surfaces and the richness of its hues generate over 60 different faces for each of the 11 colours in the collection. Pigmento's infinite colour combinations are a challenge to creativity, while its decisive tone variation makes every monochrome background a mosaic of different shades. The Lustrò decoration adds a gloss finish to the colour to create a scattered inlay of light points and tone-on-tone patterns.

La délicate progression de la surface mate et la richesse des tons chromatiques génèrent plus de 60 versions différentes pour chacune des 11 couleurs de la collection. Les combinaisons infinies de couleurs de Pigmento représentent un défi pour la créativité, tandis que ses fortes nuances font de chaque fond monochrome une mosaïque de nuances. Le décor Lustrò étend un voile brillant sur la couleur, pour des apports de lumière dispersés ou pour des créations ton sur ton.



pigmento verde, bianco, lustrò verde

pigmento verde, bianco, lustrò verde



pigmento bianco, azzurro, ocre, lustro azzurro



pigmento nero, fango, grigio, bianco



pigmento terra, beige, lustro beige

pigmento blu



pigmento bianco, ocra, malva



pigmento fango, grigio

PIGMENTO

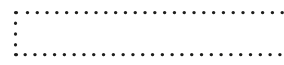

6x37cm
2.4"x14.5"

8MM

Gres porcellanato
Porcelain stoneware



Stonizzato
Shade variation

V3



Matt
Matt



Materiale riciclato
Recycled Content

43%

BIANCO PGM101M ■ 07

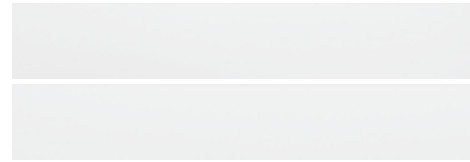

BEIGE PGM110M ■ 07



GRIGIO PGM102M ■ 07

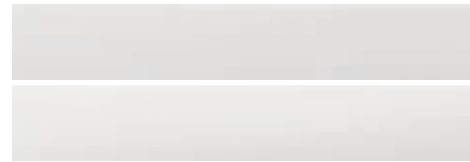

OCRA PGM109M ■ 07



FANGO PGM103M ■ 07



TERRA PGM108M ■ 07



NERO PGM104M ■ 07

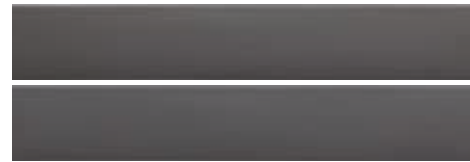

VERDE PGM107M ■ 07

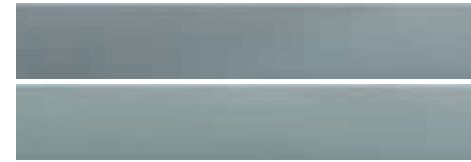

MALVA PGM105M ■ 07

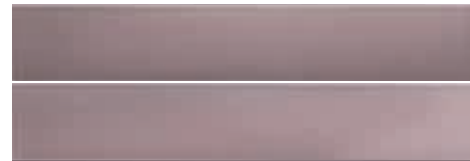

AZZURRO PGM106M ■ 07

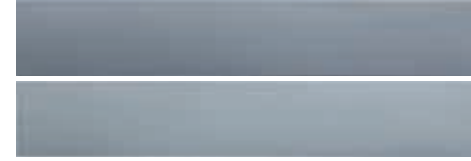

BLU PGM111M ■ 07

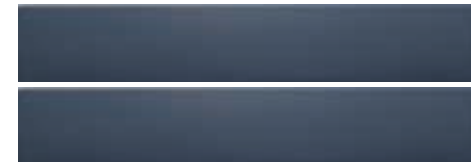

DECORO LUSTRO
BIANCO PGM301L ● 13

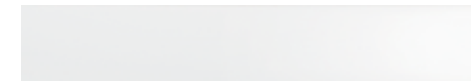

DECORO LUSTRO
BEIGE PGM310L ● 13



DECORO LUSTRO
GRIGIO PGM302L ● 13



DECORO LUSTRO
OCRA PGM309L ● 13



DECORO LUSTRO
FANGO PGM303L ● 13



DECORO LUSTRO
TERRA PGM308L ● 13



DECORO LUSTRO
NERO PGM304L ● 13



DECORO LUSTRO
VERDE PGM307L ● 13



DECORO LUSTRO
MALVA PGM305L ● 13



DECORO LUSTRO
AZZURRO PGM306L ● 13



DECORO LUSTRO
BLU PGM311L ● 13



Imballi | Packing

ARTICOLO ITEM	FORMATO SIZE	SCATOLA BOX			PALLET PALLET			
		PZ	MQ	KG	BOX	PZ	MQ	KG
Pigmento	6X37cm 2.4"x14.5"	46	1	18,90	50	2300	50	965
Pigmento lustro	6X37cm 2.4"x14.5"	6	/	2,46				

Dimensioni | Sizing

Piastrelle non rettificate soggette a lievi differenze di calibro.
 Non-rectified tiles subject to slight differences in calibre.
 Carreaux non rectifiés pouvant comporter de légères différences de calibre.

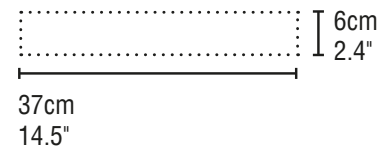

Fuga | Joint

Fuga minima 3mm. Compensare differenze di calibro con la fuga.
 Minimum 3mm joint. Compensate for differences in caliber with the joint.
 Joint d'au moins 3mm. Compenser les différences de calibre avec le joint.

QC MORE +

Scansiona il QR per accedere a info aggiuntive su:
 - Colori NCS | Stucchi
 - Schemi di posa
 - Caratteristiche tecniche



Scan the QR code to access additional information on:
 - Colour NCS | Grouts
 - Laying patterns
 - Technical characteristics

Scanne le QR code pour accéder aux informations successives sur:
 - Couleurs NCS | Joints
 - Schémas d'installation
 - Les caractéristiques techniques

Colori NCS | NCS Colours

Bianco	NCS S 1002-G50Y
Grigio	NCS S 2500-N
Fango	NCS S 4500-N
Nero	NCS S 7000-N
Blu	NCS S 6010-R90B
Terra	NCS S 4030-Y60R
Ocra	NCS S 2030-Y20R
Beige	NCS S 2005-Y30R
Azzurro	NCS S 4010-R90B
Verde	NCS S 4010-B70G
Malva	NCS S 4010-R10B

Abbinamenti consigliati | Suggested combinations

Oltre, Minima8.6, Alchimia, Pigmento10, Färgblock, Tinte, 3Lati, Modulo, Confetti, Marea, Sfumature, Riquadri, Cromie26, Genesi

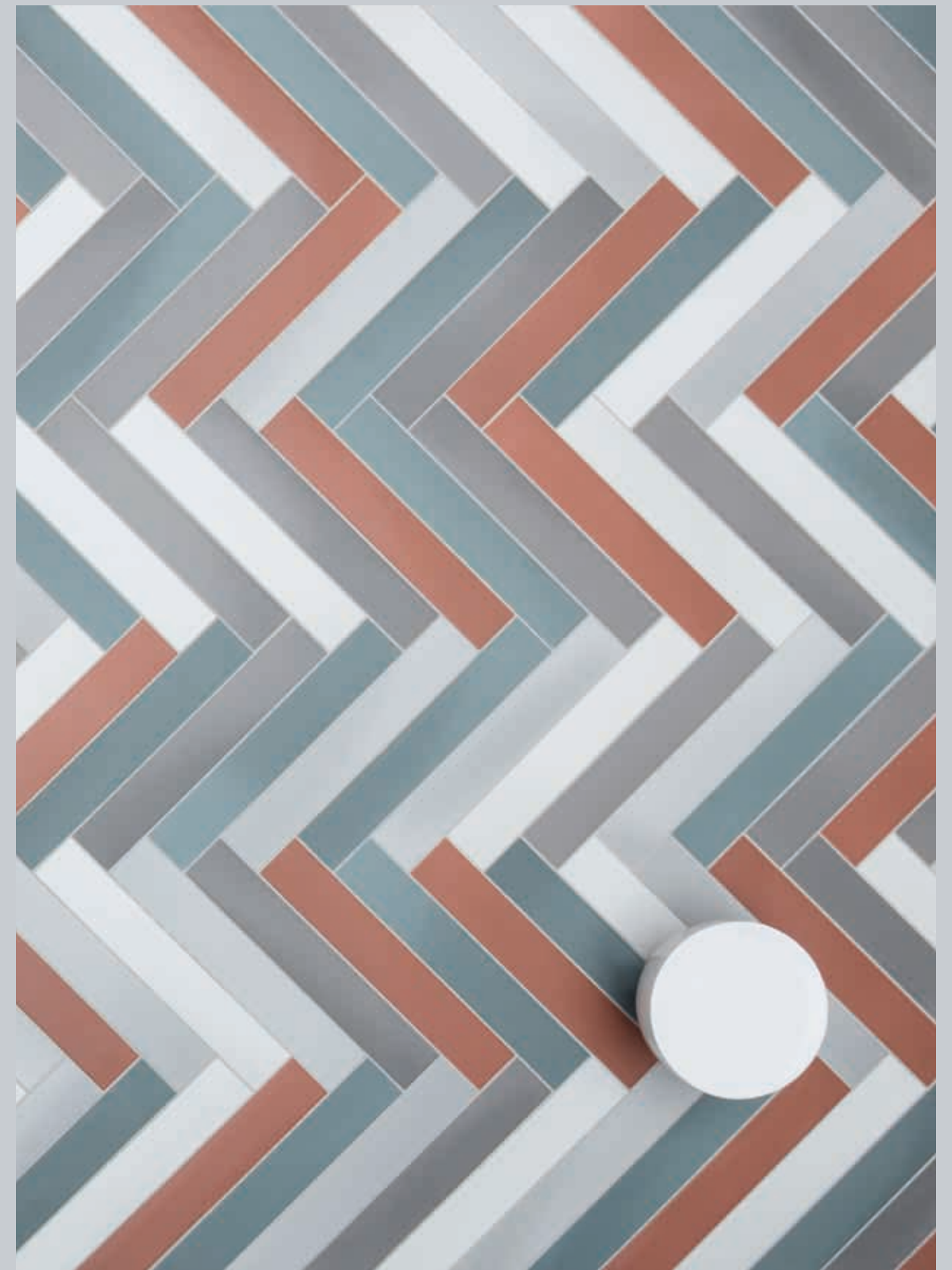

pigmento bianco, grigio, fango, verde, terra

MODULO

Gres porcellanato
Porcelain stoneware



Monocromatico
Monochromatic

V1



Matt
Matt



Materiale riciclato
Recycled Content

43%



5,6x23,2CM
2.2"x9.1"

8MM

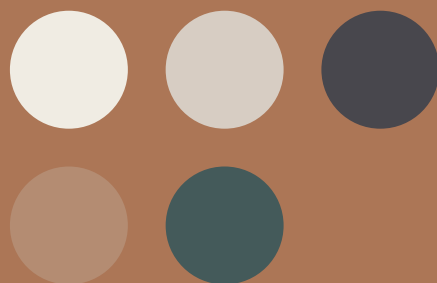

Scopri di più
su Modulo
Discover more
about Modulo

Grandi potenzialità espressive. Per consistenza materica e per suggestioni visive Modulo ammicca al mattone forato. Modulo è disponibile in due strutture superficiali, una planare (Modulo Base) e una rigata (Modulo Inciso), formale omaggio al laterizio di ispirazione. Completa la collezione il decoro "Tondi", dai bottoni di smalto lucido che mimano i fori del mattone alleggerito. Le superfici opache, assorbono la luce restituendo in purezza i cinque colori della collezione: il classico color mattone, l'elegante carbone, il grigio polvere, il bianco gesso e un intenso verde muschio.



modulo inciso mattone



Great expressive potential. In terms of its material texture and visual appeal, Modulo flirts with the style of perforated bricks. Modulo is available in two surface structures, one smooth (Modulo Base) and one ribbed (Modulo Inciso), a formal tribute to the brickwork it is inspired by. The collection is completed by "Tondi" decorative tiles featuring small gloss-glaze buttons that imitate the holes in perforated bricks. The matt surfaces of these tiles absorb light to enhance the purity of the collection's five colours: classic brick, elegant coal, powder grey, chalk white and an intense moss green.

Grand potentiel d'expression. Pour la cohérence des matériaux et les suggestions visuelles, Modulo fait un clin d'œil à la brique perforée. Modulo est disponible en deux finitions, une plane (Modulo Base) et une striée (Modulo Inciso), un hommage formel à la brique d'inspiration. La collection est complétée par le décor "Tondi", avec des boutons en émail brillant qui imitent les trous de la brique allégée. Les surfaces opaques absorbent la lumière, restituant la pureté des cinq couleurs de la collection: la couleur brique classique, l'élégant anthracite, le gris poussiéreux, le blanc craie et un vert mousse intense.



modulo base polvere, base carbone,
tondi carbone

modulo base mattone, inciso mattone



modulo base muschio, inciso gesso



modulo base gesso, inciso muschio



modulo base carbone, inciso carbone, base gesso

modulo base polvere, tondi polvere

MODULO

5,6x23,2cm
2.2"x9.1"

8MM

Gres porcellanato
Porcelain stoneware

Monocromatico
Monochromatic
V1

Matt
Matt

Materiale riciclato
Recycled Content
43%

BASE GESSO MDL102M ■ 05

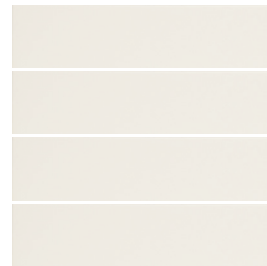

BASE POLVERE MDL104M ■ 05

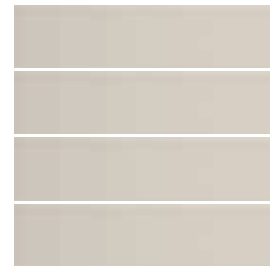

BASE MATTONE MDL106M ■ 05

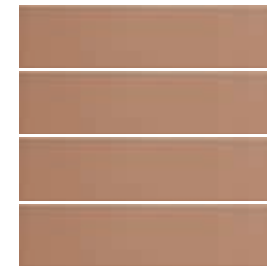

BASE CARBONE MDL108M ■ 07



BASE MUSCHIO MDL110M ■ 05

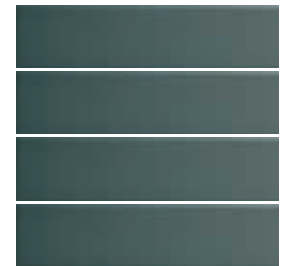

INCISO GESSO MDL101M ■ 06

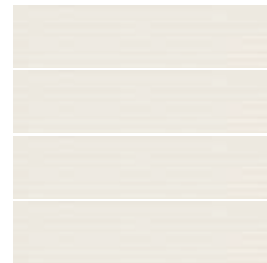

INCISO POLVERE MDL103M ■ 06

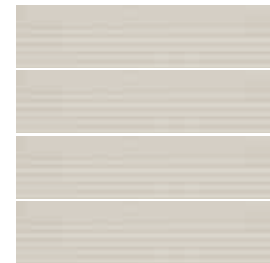

INCISO MATTONE MDL105M ■ 06



INCISO CARBONE MDL107M ■ 25



INCISO MUSCHIO MDL109M ■ 06



DECORO TONDI
GESSO MDL301M ● 15

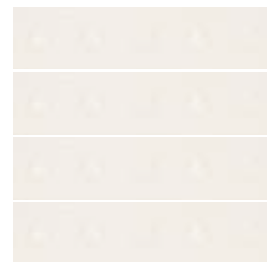

DECORO TONDI
POLVERE MDL302M ● 15



DECORO TONDI
MATTONE MDL303M ● 15



DECORO TONDI
CARBONE MDL304M ● 15

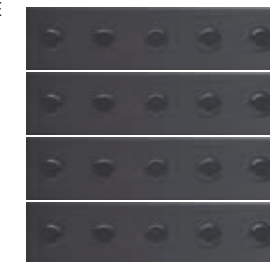

DECORO TONDI
MUSCHIO MDL305M ● 15



Imballi | Packing

ARTICOLO ITEM	FORMATO SIZE	SCATOLA BOX			PALLET PALLET			
		PZ	MQ	KG	BOX	PZ	MQ	KG
modulo base	5,6x23,2cm 2.2"x9.1"	40	0,52	8,80	95	3.800	49,40	856
modulo inciso	5,6x23,2cm 2.2"x9.1"	36	0,47	8,60	95	3.420	44,65	837
modulo tondi	5,6x23,2cm 2.2"x9.1"	4	/	0,88				

Dimensioni | Sizing

Piastrelle non rettificate soggette a lievi differenze di calibro.
 Non-rectified tiles subject to slight differences in calibre.
 Carreaux non rectifiés pouvant comporter de légères différences de calibre.

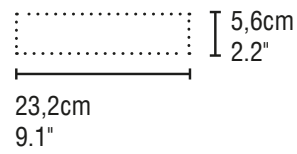

Fuga | Joint

Fuga minima 3mm. Compensare differenze di calibro con la fuga.
 Minimum 3mm joint. Compensate for differences in caliber with the joint.
 Joint d'au moins 3mm. Compenser les différences de calibre avec le joint.

Colori NCS | NCS Colours

Gesso	NCS S 0603-G80Y
Polvere	NCS S 2005-Y20R
Mattone	NCS S 3020-Y60R
Carbone	NCS S 7005-R80B
Muschio	NCS S 7010-B50G

QC MORE +

Scansiona il QR per accedere a info aggiuntive su:

- Colori NCS | Stucchi
- Schemi di posa
- Caratteristiche tecniche



Scan the QR code to access additional information on:

- Colour NCS | Grouts
- Laying patterns
- Technical characteristics

Scanne le QR code pour accéder aux informations successives sur:

- Couleurs NCS | Joints
- Schémas d'installation
- Les caractéristiques techniques

Abbinamenti consigliati | Suggested combinations

Alchimia, Oltre, Confetti, Superfici20, Minima8.6



modulo base gesso, base muschio, inciso muschio

OLTRE

Gres porcellanato
Porcelain stoneware

Monocromatic\Texture
Monochromatic\Texture
V1

Matt
Matt

Materiale riciclato
Recycled Content
43%



18,6x18,6CM
7.3"x7.3"

8MM



Scopri di più
su Oltre
Discover more
about Oltre

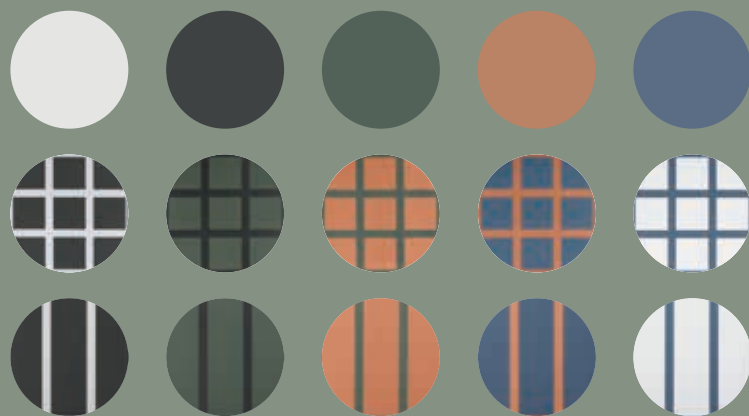

Oltre nasce da un concetto, profondo e riflessivo, interpretato in una collezione di superfici in grés porcellanato destinata a creare pavimenti, quinte e pareti dal fascino sofisticato e intellettuale. Un invito ad andare Oltre l'immaginazione pensando ad ambienti "total look" in cui si privilegia la continuità tra pavimento e rivestimento. Il risultato è un pattern infinito composto da contrasti cromatici. Ideati per garantire la massima abbinabilità, i colori di Oltre trovano la loro massima espressione in Oltre9 e Oltre3, in cui rispettivamente le sagome di 9 quadrati e 3 righe emergono dalla griglia, come piccole finestre su mondi sconosciuti.



base oltre verde, cotto, oltre9 nero.verde, verde.cotto, oltre3 bianco.nero



Oltre is based on a profound and reflective concept expressed in a collection of porcelain stoneware designed to create floors, partitions and walls with a sophisticated and intellectual charm. It is an invitation to go Oltre (beyond) imagination thanks to "total look" environments that favour a sense of continuity between floor and wall. The result is an infinite pattern of colour contrasts. Designed to guarantee ultimate mix and match versatility, the colours in the Oltre collection reach their highest level of expression in Oltre9 and Oltre3, where the shapes of 9 squares and 3 rows merge from the grid, like small windows opening onto unknown worlds.

Oltre naît d'un concept profond et réfléchi, interprété dans une collection de surfaces en grès cérame destinées à créer des sols, des ambiances et des murs au charme sophistiqué et intellectuel. Une invitation à aller Oltre (au-delà) de l'imaginaire en pensant à des ambiances "total look" dans lesquelles la continuité entre le sol et le mur est privilégiée. Le résultat est un motif infini composé de contrastes chromatiques. Conçues pour assurer une infinie palette de combinaisons, les couleurs d'Oltre trouvent leur expression maximale dans Oltre9 et Oltre3, dans lesquelles les formes de 9 carrés et 3 lignes émergent respectivement de la grille, comme de petites fenêtres sur des mondes inconnus.

base oltre blu, cotto, verde, bianco, nero,
Oltre9 blu.bianco, bianco.nero, verde.cotto, cotto.blu, nero.verde
Oltre3 blu.bianco, bianco.nero,verde.cotto, cotto.blu

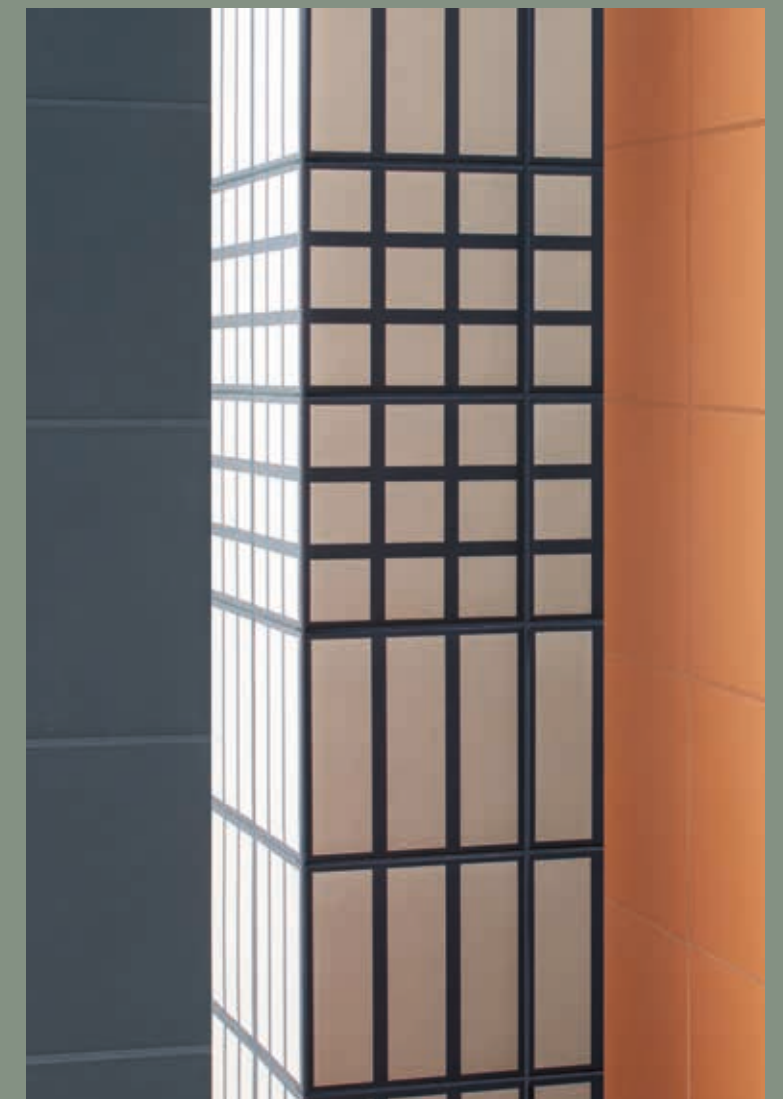

base oltre blu, cotto,
oltre9 blu.bianco, **oltre3** blu.bianco



base oltre bianco, verde, cotto, nero oltre3 verde.cotto

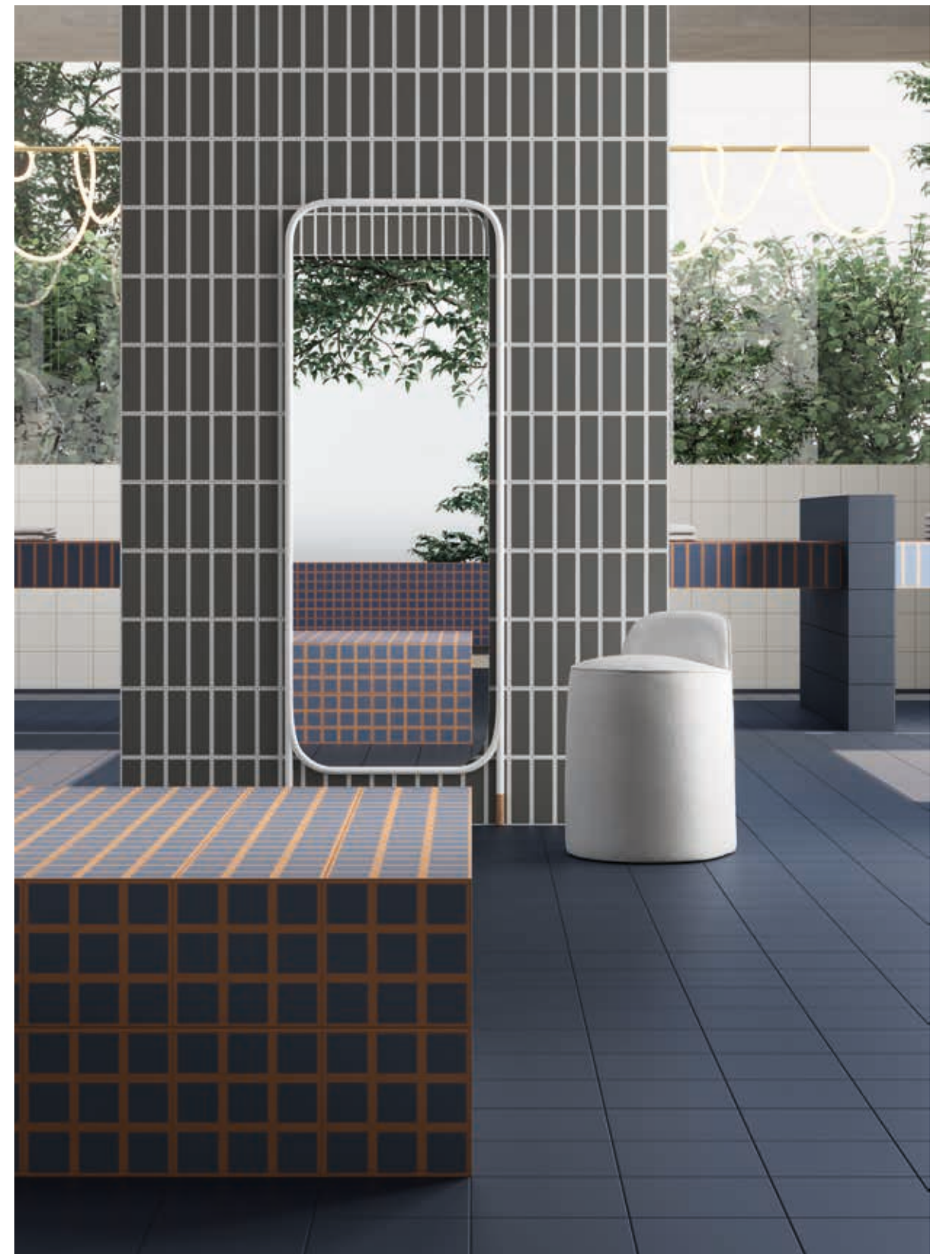

base oltre blu, bianco, oltre9 cotto.blu, oltre3 cotto.blu

base oltre blu, bianco, oltre9 cotto.blu, oltre3 bianco.nero, cotto.blu



base oltre blu, oltre9 blu.bianco, oltre3 cotto.blu, blu.bianco



base **oltre** bianco, nero, **oltre9** bianco.nero,
oltre3 nero.verde, bianco.nero



base **oltre** bianco, nero, verde, **oltre9** bianco.nero, nero.verde,
oltre3 nero.verde, bianco.nero



oltre9 nero.verde, verde.cotto,
oltre3 nero.verde, verde.cotto, base oltre verde, nero, cotto

OLTRE



18,6x18,6cm
7.3"x7.3"

8MM

Gres porcellanato
Porcelain stoneware

Monocromatico\Texture
Monochromatic\Texture

V1

Matt
Matt

Materiale riciclato
Recycled Content

43%

OLTRE9 BIANCO.NERO OTR106M ■ 05

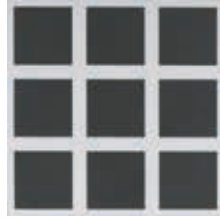

OLTRE3 BIANCO.NERO OTR111M ■ 05



BASE OLTRE BIANCO OTR101M ■ 05



OLTRE9 NERO.VERDE OTR107M ■ 05



OLTRE3 NERO.VERDE OTR112M ■ 05



BASE OLTRE NERO OTR102M ■ 05



OLTRE9 VERDE.COTTO OTR108M ■ 05

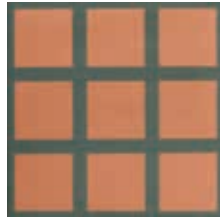

OLTRE3 VERDE.COTTO OTR113M ■ 05



BASE OLTRE VERDE OTR103M ■ 05



OLTRE9 COTTO.BLU OTR109M ■ 05

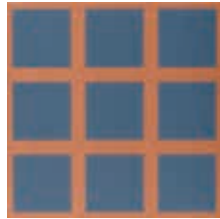

OLTRE3 COTTO.BLU OTR114M ■ 05

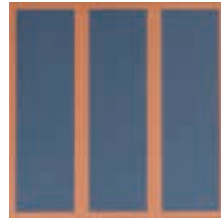

BASE OLTRE COTTO OTR104M ■ 05



OLTRE9 BLU.BIANCO OTR110M ■ 05

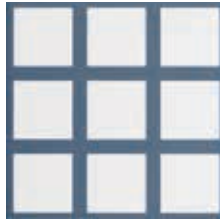

OLTRE3 BLU.BIANCO OTR115M ■ 05



BASE OLTRE BLU OTR105M ■ 05



Imballi | Packing

ARTICOLO ITEM	FORMATO SIZE	SCATOLA BOX			PALLET PALLET			
		PZ	MQ	KG	BOX	PZ	MQ	KG
oltre base	18,6x18,6cm 7.3"x7.3"	13	0,45	8,3	108	1404	48,6	920
oltre3	18,6x18,6cm 7.3"x7.3"	13	0,45	8,3	108	1404	48,6	920
oltre9	18,6x18,6cm 7.3"x7.3"	13	0,45	8,3	108	1404	48,6	920

Dimensioni | Sizing

Piastrelle non rettificate soggette a lievi differenze di calibro.
Non-rectified tiles subject to slight differences in calibre.
Carreaux non rectifiés pouvant comporter de légères différences de calibre.

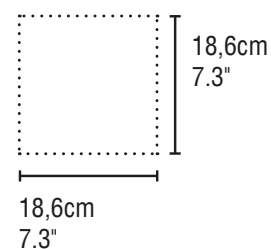
**Colori NCS | NCS Colours**

Blu	NCS S 6010 – R90B
Nero	NCS S 7500 – N
Cotto	NCS S 3030 – Y50R
Verde	NCS S 6010 – G10Y
Bianco	NCS S 0500 – N

Fuga | Joint

Fuga minima 2mm. Compensare differenze di calibro con la fuga.
Minimum 2mm joint. Compensate for differences in caliber with the joint.
Joint d'au moins 2mm. Compenser les différences de calibre avec le joint.

QC MORE +

Scansiona il QR per accedere a info aggiuntive su:
- Colori NCS | Stucchi
- Schemi di posa
- Caratteristiche tecniche



Scan the QR code to access additional information on:
- Colour NCS | Grouts
- Laying patterns
- Technical characteristics

Scanne le QR code pour accéder aux informations successives sur:
- Couleurs NCS | Joints
- Schémas d'installation
- Les caractéristiques techniques

Abbinamenti consigliati | Suggested combinations

Confetti, Färgblock, Pigmento, Modulo, Cromia26, Tinte, Marea, Porticciolo, Pigmento10



base oltre bianco, cotto, verde

CONFETTI

Gres porcellanato
Porcelain stoneware

Texture
Texture
V4

Matt
Matt

Materiale riciclato
Recycled Content
47%

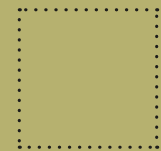

18,6x18,6CM
7.3"x7.3"

8MM



Scopri di più
su Confetti
Discover more
about Confetti

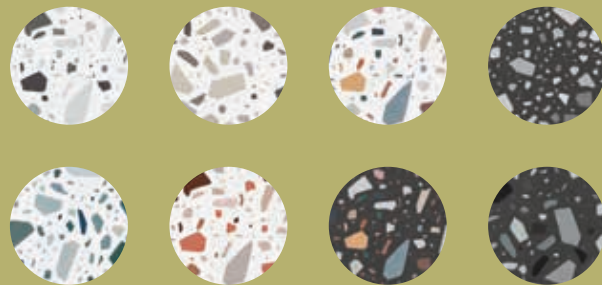

La collezione Confetti reinterpreta in chiave contemporanea i pavimenti in terrazzo e battuto alla veneziana con un grés porcellanato 18,6x18,6cm non rettificato. È caratterizzata da una mano opaca e polverosa, nella quale spiccano le scaglie colorate. Disponibile in 8 colori, 5 con fondo chiaro e 3 con fondo scuro, le tonalità degli inserti vanno dalle nuance calde dei beige e terra ai toni neutri dei grigi, ai quali si aggiungono sofisticate declinazioni sui toni blu, petrolio e azzurro e un variopinto multicolor, per una collezione che fa del movimento estetico e della gamma cromatica - perfettamente abbinabile ai rivestimenti Quintessenza - il proprio punto di forza.



confetti bianco.multicolor , bianco.cotto, nero.multicolor



The highly contemporary Confetti collection restyles Venetian Terrazzo flooring in a non-rectified, 18.6x18.6cm format porcelain stoneware. This collection stands out for its dusty, matt finish that contrasts with the coloured chips. Available in 8 colours, 5 with a light background and 3 with a dark background, and chips in shades ranging from warm tones of beige and earth to neutral greys and sophisticated hues of light and dark blue, multi-colours and petrol green. This combination creates a collection whose strength lies in its style and colours that combine perfectly with Quintessenza wall tiles.

La collection Confetti réinterprète de manière contemporaine les sols vénitiens en terrazzo, mais ici en grés cérame émaillé de 18,6x18,6cm et non rectifié. Elle est caractérisée par une finition opaque très naturelle au travers de laquelle apparaissent les points de couleurs. Disponible dans 8 couleurs, dont 5 couleurs sur un fond clair et 3 sur un fond plus foncé, les tonalités des Confetti vont des nuances chaudes des beiges et terres, aux tonalités neutres des gris, auxquelles s'ajoutent les déclinaisons sophistiquées des bleus, pétrole et azur, ainsi qu'un panaché multi-couleurs; tout cela pour une collection qui, de son mouvement esthétique et de sa gamme chromatique par ailleurs parfaitement coordonnée aux collections murales Quintessenza en fait son point de force.



confetti bianco,petrolio, nero,petrolio,
modulo base muschio, inciso muschio

confetti bianco.beige



confetti bianco.cotto, bianco.multicolor, nero.multicolor,
tinte verde matt



confetti bianco.multicolor



confetti nero.grigio,
pigmento bianco

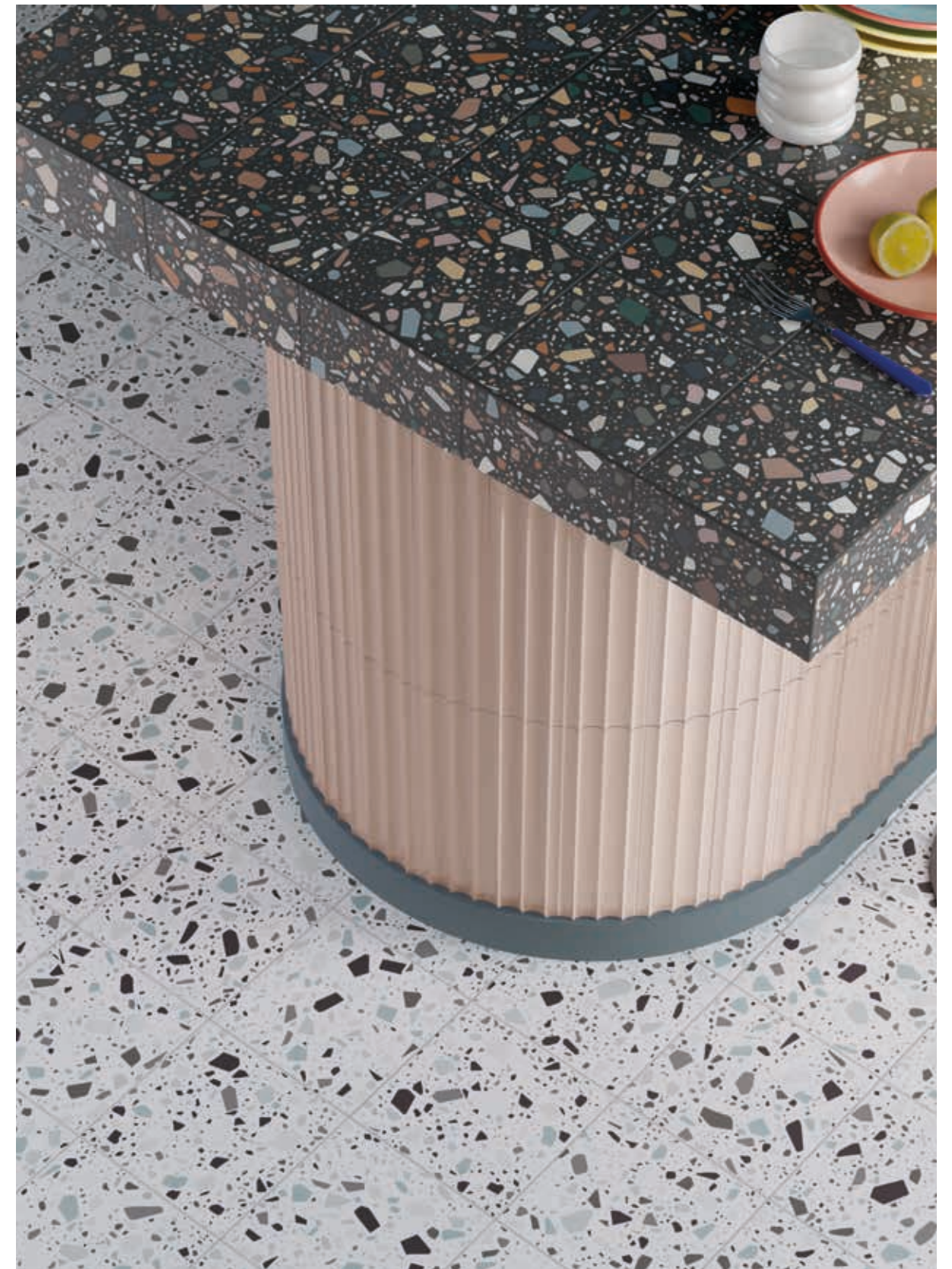

confetti nero.petrolio,
pigmento verde, malva, lustro malva

confetti bianco.grigio, nero.multicolor
bassa-marea rosa lucido

CONFETTI

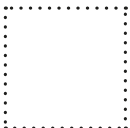

18,6x18,6cm
7.3"x7.3"

8MM

Gres porcellanato
Porcelain stoneware

Texture
Texture
V4

Matt
Matt

Materiale riciclato
Recycled Content
47%

BIANCO.BEIGE

CNF103M ■ 05

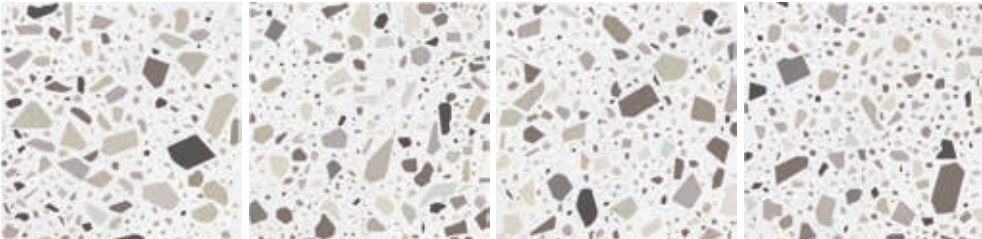

BIANCO.GRIGIO

CNF101M ■ 05

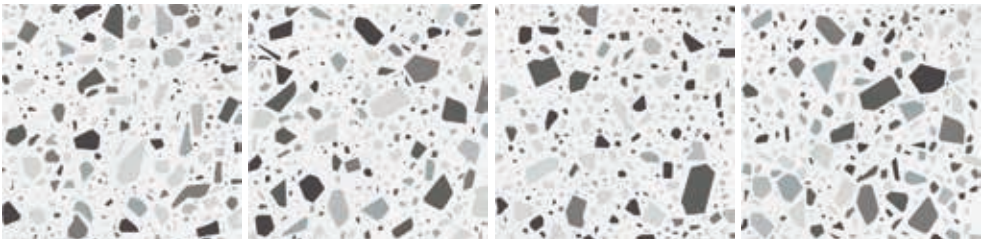

BIANCO.COTTO

CNF104M ■ 05

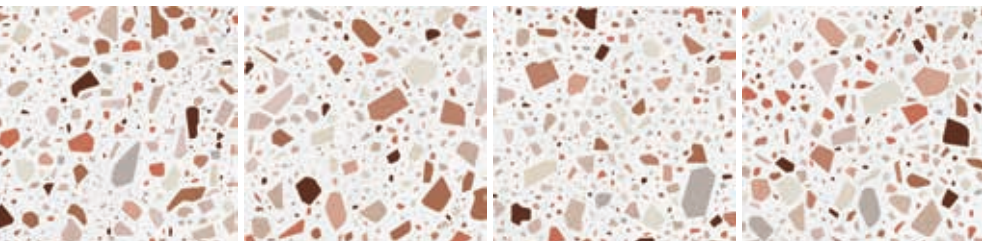

BIANCO.PETROLIO

CNF102M ■ 05

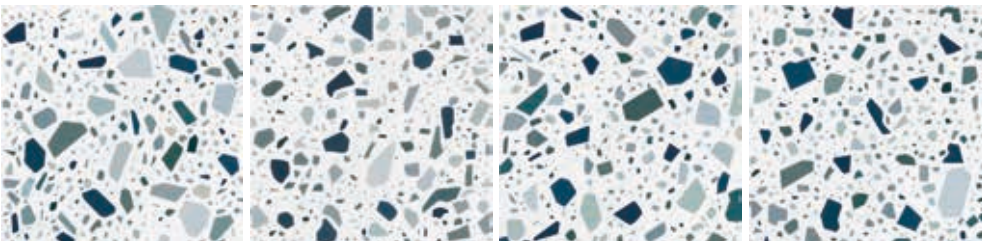

BIANCO.MULTICOLOR

CNF105M ■ 05

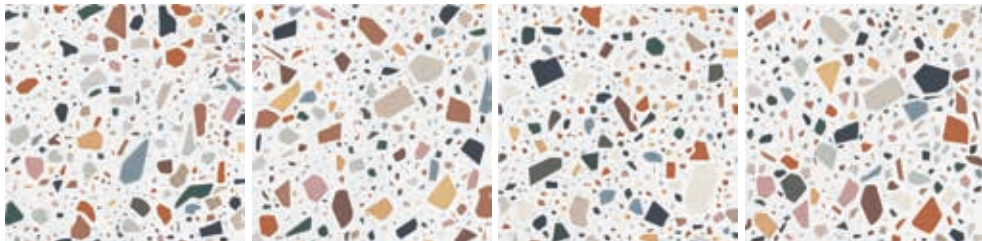

NERO.GRIGIO

CNF106M ■ 05

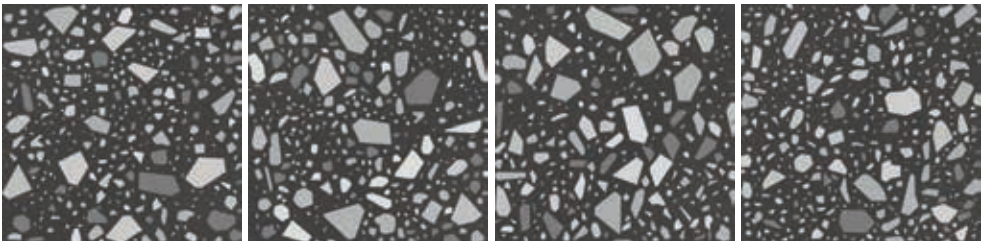

NERO.MULTICOLOR

CNF108M ■ 05

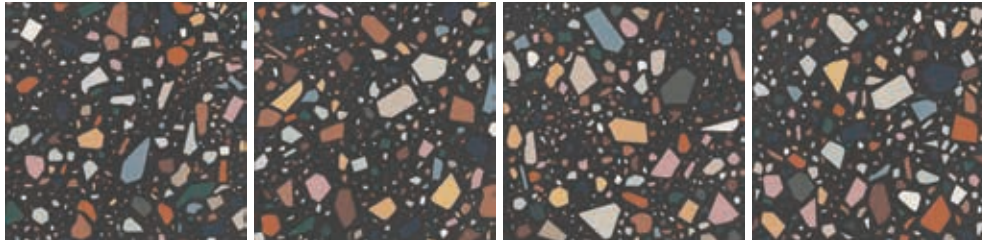

NERO.PETROLIO

CNF107M ■ 05

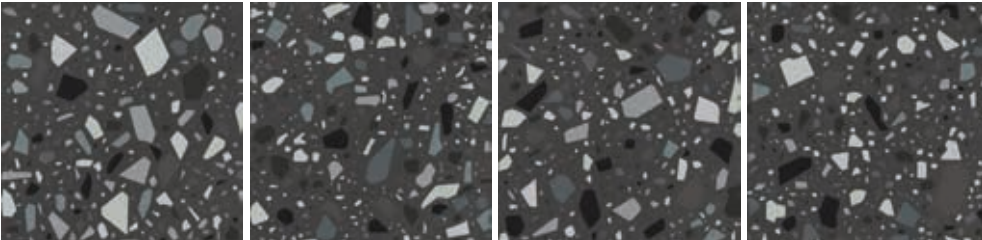

Imballi | Packing

ARTICOLO ITEM	FORMATO SIZE	SCATOLA BOX			PALLET PALLET			
		PZ	MQ	KG	BOX	PZ	MQ	KG
confetti	18,6X18,6cm 7.3"x7.3"	13	0,45	8,30	108	1404	48,60	920

Dimensioni | Sizing

Piastrelle non rettificate soggette a lievi differenze di calibro.
Non-rectified tiles subject to slight differences in calibre.
Carreaux non rectifiés pouvant comporter de légères différences de calibre.

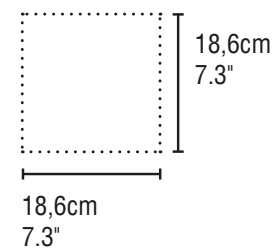
**Fuga | Joint**

Fuga minima 2mm. Compensare differenze di calibro con la fuga.
Minimum 2mm joint. Compensate for differences in caliber with the joint.
Joint d'au moins 2mm. Compenser les différences de calibre avec le joint.

QC MORE +

Scansiona il QR per accedere
a info aggiuntive su:
- Colori NCS | Stucchi
- Caratteristiche tecniche



Scan the QR code to access
additional information on:
- Colour NCS | Grouts
- Technical characteristics

Scanne le QR code
pour accéder aux informations
successives sur:
- Couleurs NCS | Joints
- Les caractéristiques techniques

Abbinamenti consigliati | Suggested combinations

Marea, Tinte, Pigmento, Pigmento10, Oltre, Färgblock, Modulo, Minima8.6, 3lati, Riquadri, Sfumature, Cromia26, Genesi



confetti bianco.petrolio

TINTE

Rivestimento in pasta bianca
White body wall tiles

Stonizzato
Shade variation
V1/V3

Matt/Lucido
Matt/Glossy

Materiale riciclato
Recycled Content
69%



5x25CM
2"x10"

9MM



Scopri di più
su Tinte
Discover more
about Tinte



Colore e materia. È il colore, modulato su diversi toni e gradi di intensità la cifra stilistica del rivestimento in pasta bianca Tinte. 12 nuance, dal bianco al nero, passando per il giallo ocra, il rosa antico, la carta da zucchero, il metallizzato e il nuovo Blu: profondo, sofisticato, ultra-contemporaneo. Il lato lungo del listello si caratterizza per il morbido bisello e per l'accumulo di pigmento, che insieme danno slancio a questo rivestimento mentre le superfici, lucide o matt ne aumentano le possibilità espressive e applicative e rappresentano un costante invito, da guardare e da toccare.



tinte blu matt



Colour and matter Colour, modulated in a series of different shades and degrees of intensity is the style driver in this Tinte white body wall tile collection. 13 shades, ranging from white to black and passing through yellow ochre, antique pink, sugar paper blue, metallic and the new Blue: deep, sophisticated and ultra-contemporary. The long side of the strip tile stands out for its gentle chamfer and pigment concentration, both of which give this wall tile a dynamic energy while the matt or gloss surfaces increase its expressiveness and application options as well as offering a constant invitation to be looked at and touched.

Couleur et Matière C'est la couleur, modulée sur différentes tonalités et degrés d'intensité qui anime cette collection de revêtement mural en pâte blanche. 13 nuances, du blanc au noir, en passant par le jaune ocre, le rose antique, le papier de sucre, le métallisé et un nouveau bleu: profond, sophistiqué, ultra-contemporain. Le côté long du listel se caractérise par un léger biseau et un intense point d'accumulation de pigment, qui ensemble donne élan à ce revêtement, alors que la surface brillante ou mat augmente les possibilités expressives et d'innombrables applications, représentant une constante invitation à regarder et à toucher.



tinte acquamarina lucido, acquamarina matt, pigmento nero

tinte acciaio lucido



tinte blu lucido, grigio medio lucido
confetti bianco.petrolio

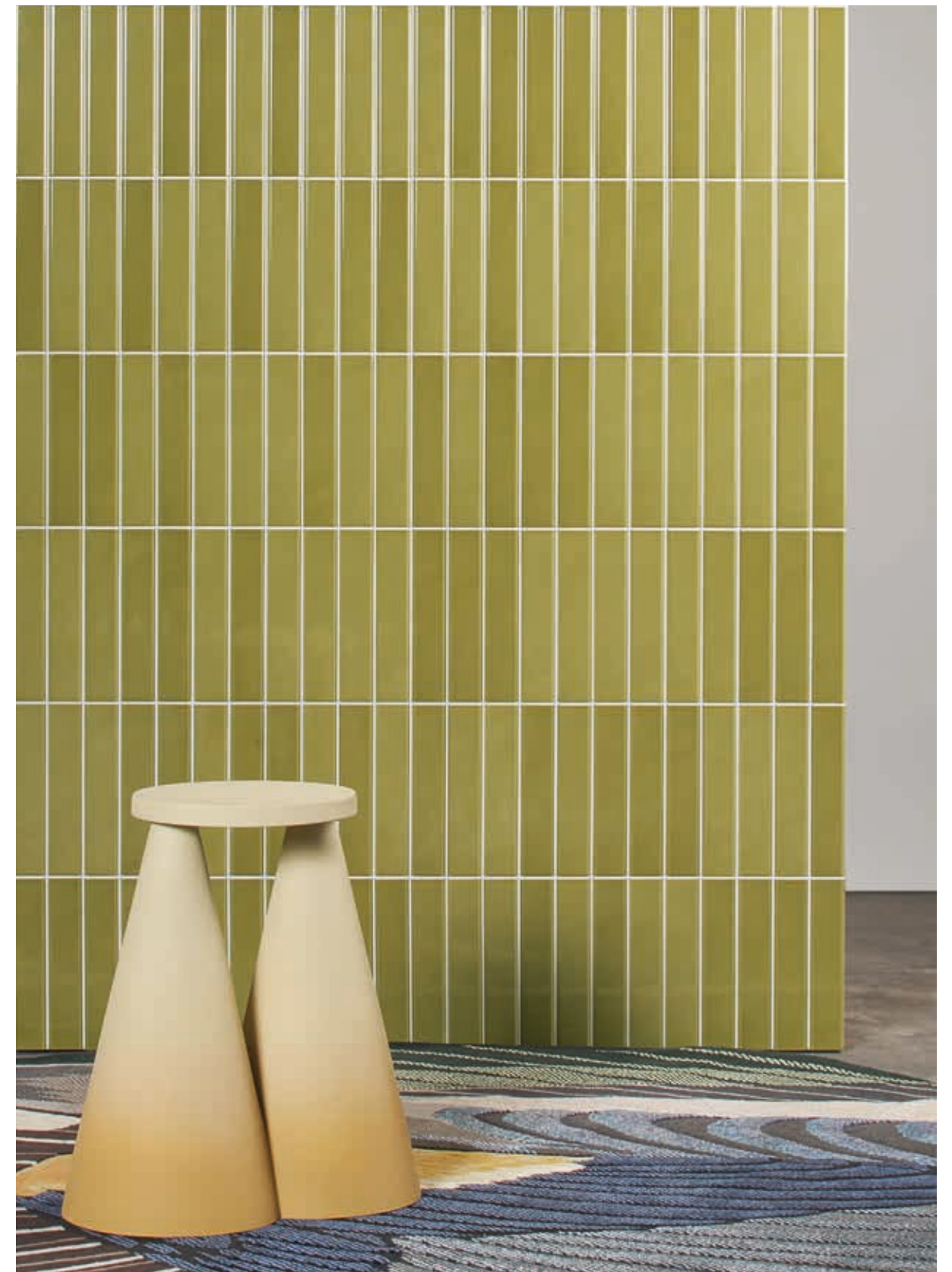

tinte verde lucido

tinte fango lucido, fango matt,
confetti bianco.beige



tinte rosa matt



tinte carta da zucchero matt, carta da zucchero lucido, nero matt, nero lucido
confetti bianco.petrolio



↖ LOUNGE
→ TERRACE

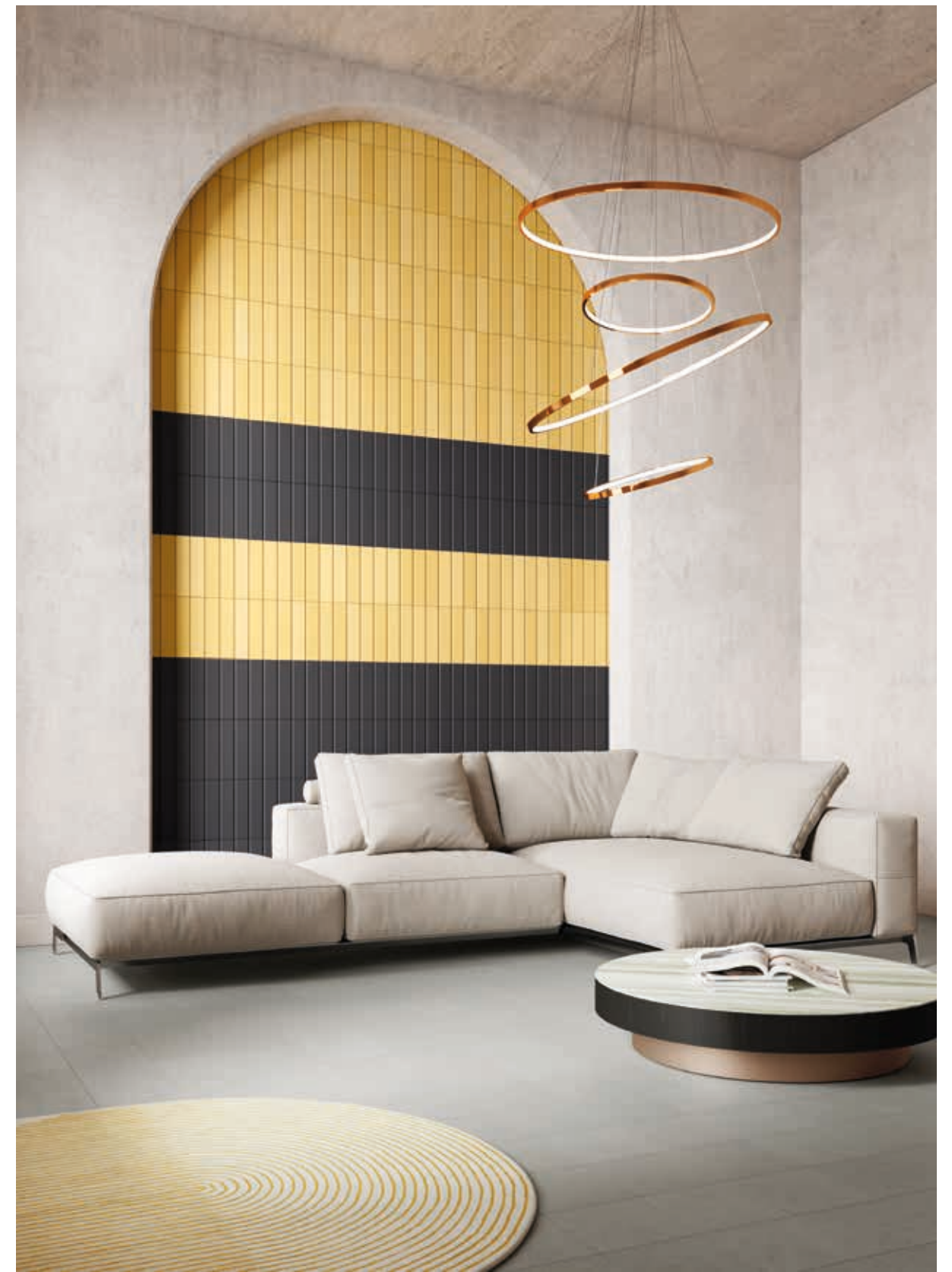

tinte grigio medio lucido, grigio medio matt

tinte giallo matt, nero matt,
superfici20 cemento perla

5x25cm
2"x10"

9MM

Rivestimento in pasta bianca
White body wall tiles

Stonalizzato
Shade variation

Matt/Lucido
Matt/Glossy

Materiale riciclato
Recycled Content

V1/V3

69%

BIANCO LUCIDO TNT101L ■ 02



BIANCO MATT TNT115M ■ 02



CARTA DA ZUCCHERO LUCIDO TNT108L ■ 02



CARTA DA ZUCCHERO MATT TNT121M ■ 02



GRIGIO CHIARO LUCIDO TNT102L ■ 02

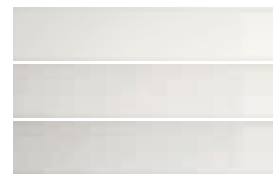

GRIGIO CHIARO MATT TNT116M ■ 02

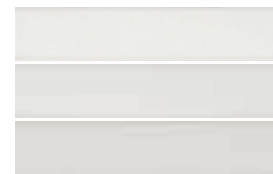

BLU LUCIDO TNT114L ■ 02



BLU MATT TNT126M ■ 02

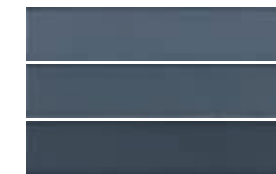

GRIGIO MEDIO LUCIDO TNT103L ■ 02

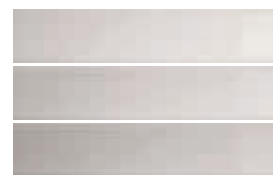

GRIGIO MEDIO MATT TNT117M ■ 02

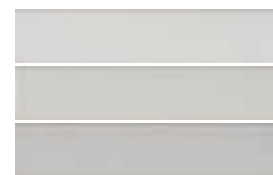

GIALLO LUCIDO TNT109L ■ 02



GIALLO MATT TNT123M ■ 02



TORTORA LUCIDO TNT104L ■ 02



TORTORA MATT TNT118M ■ 02

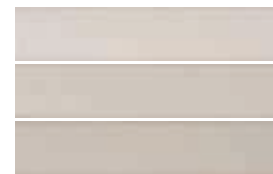

VERDE LUCIDO TNT110L ■ 02



VERDE MATT TNT124M ■ 02

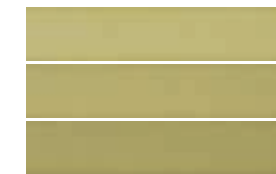

FANGO LUCIDO TNT105L ■ 02



FANGO MATT TNT122M ■ 02



NERO LUCIDO TNT111L ■ 04

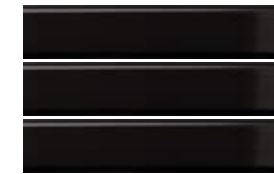

NERO MATT TNT125M ■ 04

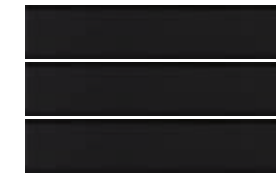

ROSA LUCIDO TNT106L ■ 02



ROSA MATT TNT119M ■ 02

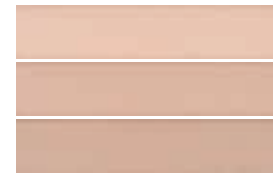

ACCIAIO LUCIDO TNT112L ■ 14



ATTENZIONE - PIASTRELLE CON COLORI METALLICI: ⚠️
I colori metallizzati sono realizzati con smalti speciali che tendono ad avere un effetto crackle naturale e una bassa resistenza a prodotti acidi ed alcalini. Non utilizzare prodotti di pulizia aggressivi, come candeggina e ammoniaca. Consultare la guida per l'installazione e la manutenzione a pag. 242

WARNING - TILES WITH METALLIC COLORS: ⚠️
Metallic colors are made with special glazes that tends to have a natural crackle effect and low resistance to acidic and alkaline cleaning products. Do not use aggressive cleaning products, such as bleach or ammonia. Check the installation and maintenance guide on page 244

ATTENTION - CARREAUX AVEC ÉMAUX MÉTALLIQUES: ⚠️
les couleurs métallisées sont réalisées avec des émaux spéciaux qui tendent à avoir un effet craquelé naturel et une basse résistance aux produits acides et alcalins. Ne pas utiliser de produits agressifs pour le nettoyage comme l'eau de javel ou l'ammoniaque. Consultez les conseils d'instructions de pose et d'entretien page 246

Stonalizzato
Shade variation

V1

nero lucido/matt, acciaio lucido, bianco lucido/matt

V3

grigio chiaro lucido/matt, grigio medio lucido/matt, tortora lucido/matt, fango lucido/matt, rosa lucido/matt, acquamarina lucido/matt, carta da zucchero lucido/matt, blu lucido/matt, giallo lucido/matt, verde lucido/matt

Imballi | Packing

ARTICOLO ITEM	FORMATO SIZE	SCATOLA BOX			PALLET PALLET			
		PZ	MQ	KG	BOX	PZ	MQ	KG
Tinte matt	5x25cm 2x10"	40	0,50	7,10	90	3.600	45,00	660
Tinte lucido	5x25cm 2x10"	40	0,50	7,10	90	3.600	45,00	660

Dimensioni | Sizing

Piastrelle non rettificate | Non-rectified tiles
Carreaux non rectifiés

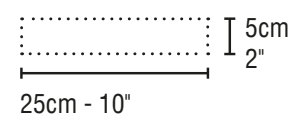
**Posa | Posa**

Istruzioni di posa per piastrelle con variazione cromatica:
si consiglia di prelevare le piastrelle da più scatole contemporaneamente
per garantire una corretta stonalizzazione che esalti la variabilità
e la casualità della superficie finita.

Laying instructions for tiles with colour variation:
it is recommended to take tiles from several boxes at a time
to ensure proper shade variation that enhances the variability
and randomness of the finished surface.

Il est recommandé de prélever des carreaux de plusieurs boîtes
en même temps pour garantir une pose plus homogène améliorant
ainsi la variabilité et le caractère aléatoire de la surface finie.

Colori NCS | NCS Colours

	Lucidi	Matt
Bianco	NCS S 0300-N	NCS S 0500-N
Grigio Chiaro	NCS S 1002-Y	NCS S 1002-Y
Grigio Medio	NCS S 2000 N	NCS S 2000 N
Tortora	NCS S 2005-Y20R	NCS S 2005-Y50R
Fango	NCS S 4005-Y50R	NCS S 5005-Y50R
Rosa	NCS S 1515-Y70R	NCS S 1515-Y70R
Acquamarina	NCS S 3010-G	NCS S 3010-G
Carta da zucchero	NCS S 3010-B10G	NCS S 3010-B
Blu	NCS S 7020-R90B	NCS S 7010-R90B
Giallo	NCS S 1050 Y10R	NCS S 1050 Y10R
Verde	NCS S 3040-G70Y	NCS S 3040-G70Y
Nero	NCS S 9000-N	NCS S 8000-N

Abbinamenti consigliati | Suggested combinations

Confetti, Oltre, Pigmento, Minima8.6, Alchimia, Superfici20, Pigmento10

Fuga | Joint

Fuga minima 2mm | Minimum joint 2mm
Joint d'au moins 2mm

QC MORE +

Scansiona il QR per accedere
a info aggiuntive su:
- Colori NCS | Stucchi
- Schemi di posa
- Caratteristiche tecniche



Scan the QR code to access
additional information on:
- Colour NCS | Grouts
- Laying patterns
- Technical characteristics

Scanne le QR code
pour accéder aux informations
successives sur :
- Couleurs NCS | Joints
- Schémas d'installation
- Les caractéristiques techniques



tinte blu lucido, blu matt
confetti bianco.multicolor

3LATI

Rivestimento in pasta bianca
White body wall tiles

 Stonizzato
Shade variation
V1/V3

 Lucido
Glossy

 Materiale riciclato
Recycled Content
69%

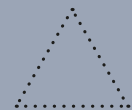

13,2x11,4cm
5.2"x4.5"

 9MM



Scopri di più
su 3Lati
Discover more
about 3Lati

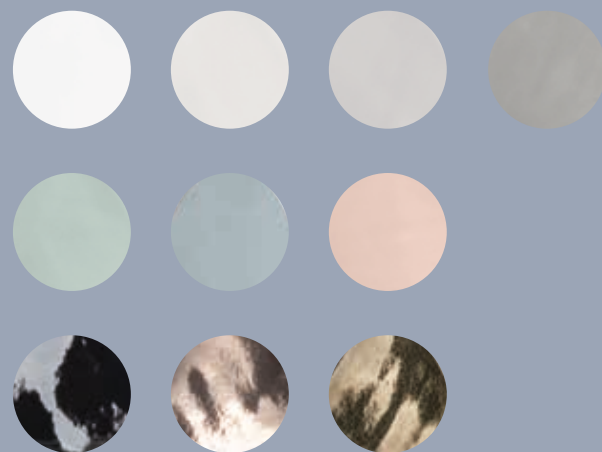

Una collezione da rivestimento che fa del triangolo l'elemento base di un'estetica minuta modulabile all'infinito. I colori consentono grafismi sofisticati, giocati ora su contrasti cromatici forti, ora su delicati passaggi di tono. Ogni tinta è infatti declinata su più gradi di intensità. Lo smalto lucido della superficie, dalla struttura mossa ma morbida, raccoglie e rilancia la luce, insieme a scaglie di colore.

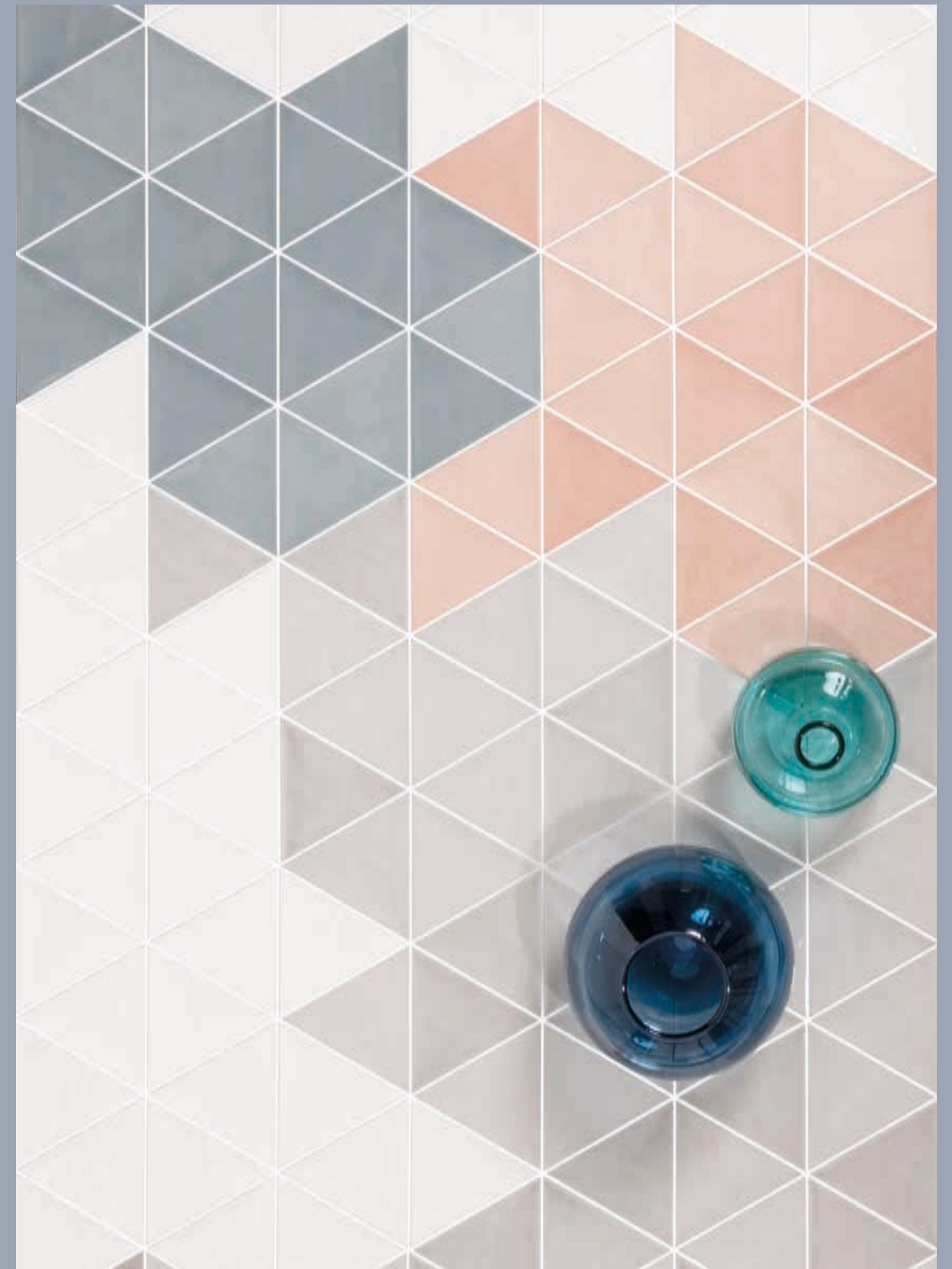

3lati bianco, rosa, carta da zucchero, grigio medio

This wall tile collection uses the triangle as the base element of a meticulous, infinitely modular style. The colours create sophisticated graphic patterns, with both powerful contrasts and delicate shifts in tone. The gloss glaze of the surface and its soft and fluid structure, collects and reflects light and slivers of colour.

Une collection de revêtements muraux qui fait du triangle l'élément de base d'une esthétique minutieuse modulable à l'infini. Les couleurs permettent des graphismes sophistiqués, jouant tantôt sur de forts contrastes chromatiques, tantôt sur de délicates transitions de tons. Chaque teinte est en effet disponible en plusieurs degrés d'intensité. L'émail brillant de la surface, à la structure ondulée mais douce, capte et relance la lumière, ainsi que des flocons de couleur.

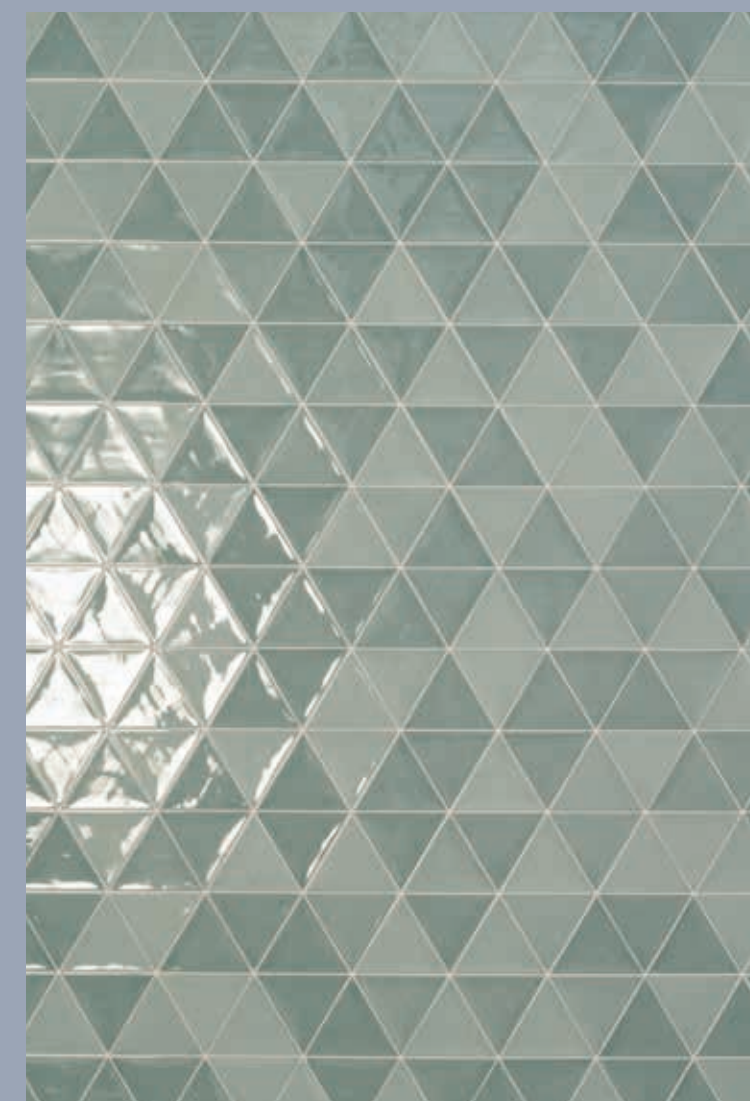

3lati rosa
riquadri carta da zucchero

3lati acquamarina



3lati grigio scuro,
riquadri base grigio scuro

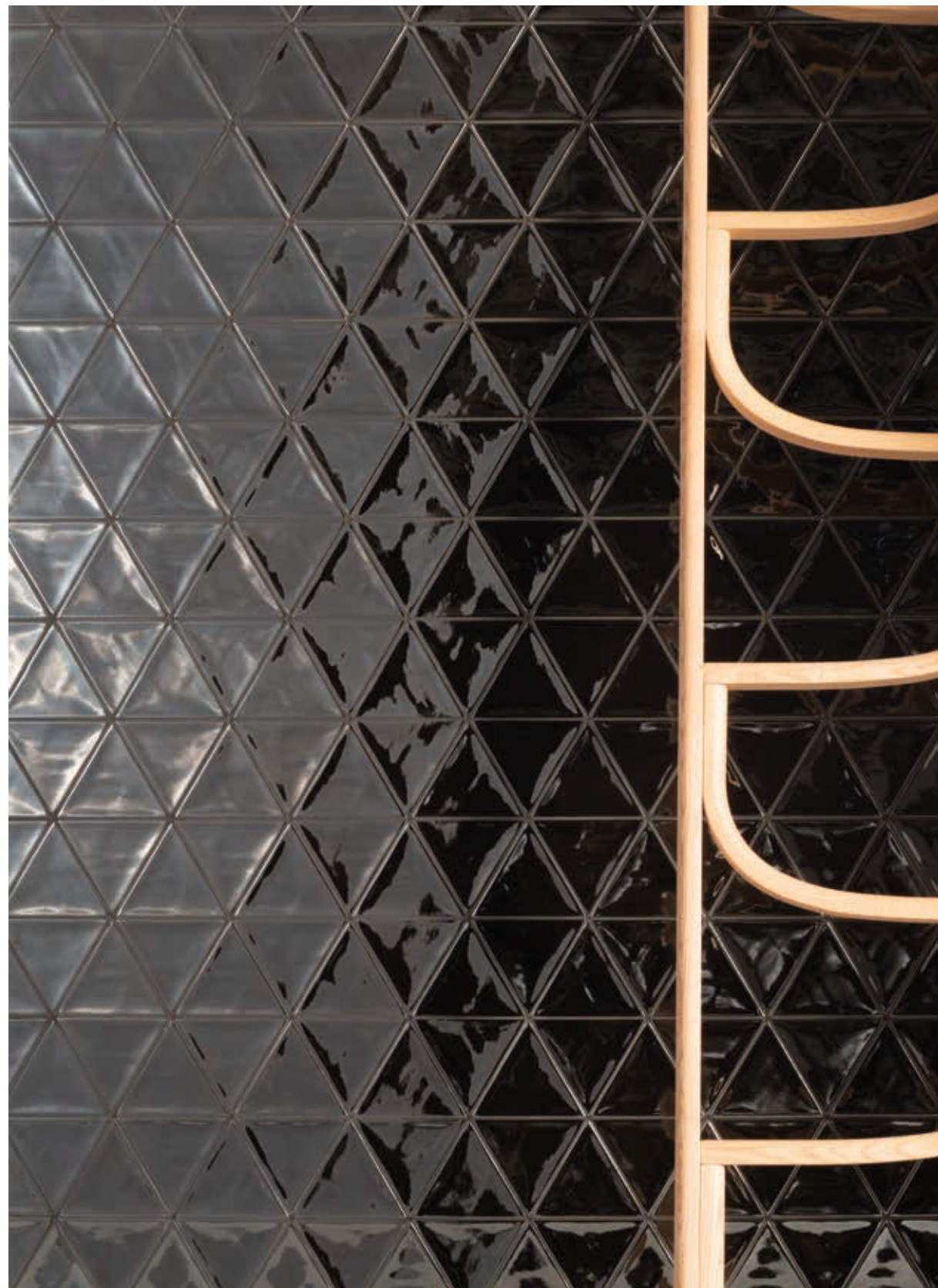

3lati riflessi acciaio



3lati bianco, grigio chiaro, grigio medio, carta da zucchero
superfici20 cemento perla



13,2x11,4cm
5.2"x4.5"

9MM

Rivestimento in pasta bianca
White body wall tiles

Stonalizzato
Shade variation

V1/V3

Lucido
Glossy

Materiale riciclato
Recycled Content

69%

BIANCO LUCIDO

TRL101L ■23



GRIGIO CHIARO LUCIDO

TRL102L ■23



GRIGIO MEDIO LUCIDO

TRL103L ■23



GRIGIO SCURO LUCIDO

TRL104L ■23



ACQUAMARINA LUCIDO

TRL107L ■23



CARTA DA ZUCCHERO LUCIDO

TRL105L ■23



ROSA LUCIDO

TRL106L ■23



ACCIAIO

TRL110L ■24



BRONZO

TRL108L ■24



ORO

TRL109L ■24



Stonalizzato
Shade variation

V1 bianco, acciaio, bronzo, oro

V3 grigio chiaro, grigio medio, grigio scuro, acquamarina, carta da zucchero, rosa

ATTENZIONE - PIASTRELLE CON COLORI METALLICI: I colori metallizzati sono realizzati con smalti speciali che tendono ad avere un effetto crackle naturale e una bassa resistenza a prodotti acidi ed alcalini. Non utilizzare prodotti di pulizia aggressivi, come candeggina e ammoniaca. Consultare la guida per l'installazione e la manutenzione a pag. 242

WARNING - TILES WITH METALLIC COLORS: Metallic colors are made with special glazes that tends to have a natural crackle effect and low resistance to acidic and alkaline cleaning products. Do not use aggressive cleaning products, such as bleach or ammonia. Check the installation and maintenance guide on page 244

ATTENTION - CARREAUX AVEC ÉMAUX MÉTALLIQUES: les couleurs métallisées sont réalisées avec des émaux spéciaux qui tendent à avoir un effet craquelé naturel et une basse résistance aux produits acides et alcalins. Ne pas utiliser de produits agressifs pour le nettoyage comme l'eau de javel ou l'ammoniaque. Consultez les conseils d'instructions de pose et d'entretien page 246

Imballi | Packing

ARTICOLO ITEM	FORMATO SIZE	SCATOLA BOX			PALLET PALLET			
		PZ	MQ	KG	BOX	PZ	MQ	KG
3Lati	13,2x11,4cm 5.2"x4.5"	30	0,23	3,67	126	3.780	28,98	482

Dimensioni | Sizing

Piastrelle non rettificate | Non-rectified tiles
Carreaux non rectifiés

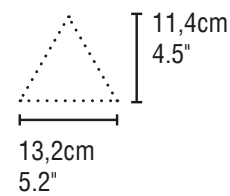
**Posa | Posa**

Istruzioni di posa per piastrelle con variazione cromatica:
si consiglia di prelevare le piastrelle da più scatole contemporaneamente
per garantire una corretta stonalizzazione che esalti la variabilità
e la casualità della superficie finita.

Lying instructions for tiles with colour variation:
it is recommended to take tiles from several boxes at a time
to ensure proper shade variation that enhances the variability
and randomness of the finished surface.

Il est recommandé de prélever des carreaux de plusieurs boîtes
en même temps pour garantir une pose plus homogène améliorant
ainsi la variabilité et le caractère aléatoire de la surface finie.

Colori NCS | NCS Colours

Bianco	NCS S 0300-N
Grigio Chiaro	NCS S 1002-Y
Grigio Medio	NCS S 2000-N
Grigio Scuro	NCS S 3502-Y
Carta Da Zucchero	NCS S 3010-B10G
Acquamarina	NCS S 3010-G
Rosa	NCS S 1515-Y70R

Abbinamenti consigliati | Suggested combinations

Confetti, Pigmento, Riquadri, Genesi, Alchimia, Oltre

Fuga | Joint

Fuga minima 2mm | Minimum joint 2mm
Joint d'au moins 2mm

Modularità | Modularity

La serie 3Lati è modulare per formato e gamma cromatica
con il rivestimento Riquadri.

The 3Lati collection is modular by format and color range
with Riquadri wall tile Collection.

La série 3Lati est modulable par format et couleur
avec la série Riquadri.

QC MORE +

Scansiona il QR per accedere
a info aggiuntive su:
- Colori NCS | Stucchi
- Caratteristiche tecniche



Scan the QR code to access
additional information on:
- Colour NCS | Grouts
- Technical characteristics

Scanne le QR code
pour accéder aux informations
successives sur:
- Couleurs NCS | Joints
- Les caractéristiques techniques



3lati oro

RIQUADRI

Rivestimento in pasta bianca
White body wall tiles

 Stonizzato
Shade variation
V1/V3

 Lucido
Glossy

 Materiale riciclato
Recycled Content
69%



13,2x26,6cm
5.2"x10.5"

 9MM

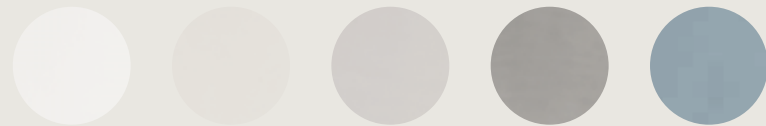

Scopri di più
su Riquadri
Discover more
about Riquadri

La sottolineatura grafica della forma rettangolare si aggiunge con discrezione alla base, raddoppiando le possibilità espressive e stabilendo la cifra estetica di questa collezione da rivestimento. Cinque colori armonicamente miscelabili tra loro di cui il bianco, nelle due varianti, vive della propria purezza mentre gli altri si scandiscono su varie densità cromatiche per le basi e altrettante per i riquadri.



riquadri grigio chiaro



Here, the rectangular format of the tiles is discreetly emphasized by a graphic frame running around each rectangle, thereby doubling the expressive power of this format and giving the entire wall collection a highly distinctive style. Five colours, including two variants of white, combine harmoniously to create a distinctively pure effect, while the others offer a range of different colour densities for both the bases and the frames.

Le soulignement graphique de la forme rectangulaire est ajouté discrètement à la base, doublant les possibilités expressives et confirmant ainsi la caractéristique esthétique de cette collection de revêtement mural. Cinq couleurs qui peuvent être harmonieusement mélangées entre elles, dont le blanc, dans les deux variantes, éclatant et lumineux et les autres couleurs s'articulant sur différentes densités chromatiques tant sur la base que sur le contour.



riquadri carta da zucchero

riquadri bianco



riquadri grigio scuro



riquadri base bianco
3lati bianco

RIQUADRI



13,2x26,6cm
5.2"x10.5"

9MM

Rivestimento in pasta bianca
White body wall tiles

Stonalizzato
Shade variation

Lucido
Glossy

Materiale riciclato
Recycled Content

V1/V3

69%

BASE BIANCO

RQD101L ■ 02

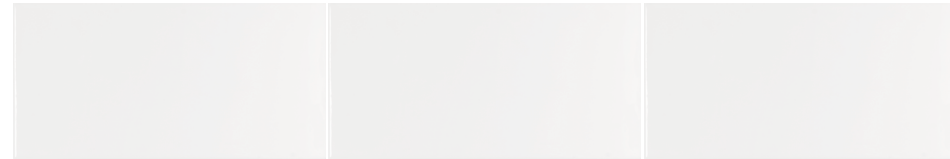

BASE GRIGIO CHIARO

RQD102L ■ 02



BASE GRIGIO MEDIO

RQD103L ■ 02



BASE GRIGIO SCURO

RQD104L ■ 02



BASE CARTA DA ZUCCHERO

RQD105L ■ 02



RIQUADRI BIANCO

RQD106L ■ 02

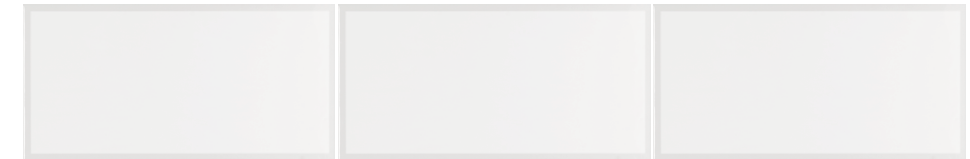

RIQUADRI GRIGIO CHIARO

RQD107L ■ 02

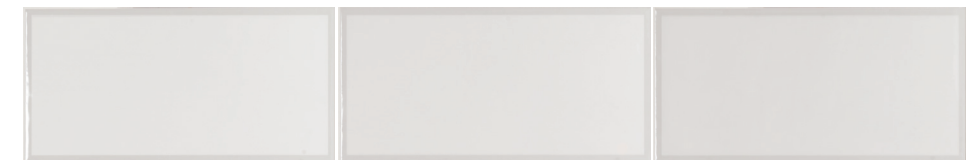

RIQUADRI GRIGIO MEDIO

RQD108L ■ 02



RIQUADRI GRIGIO SCURO

RQD109L ■ 02



RIQUADRI CARTA DA ZUCCHERO

RQD110L ■ 02



Stonalizzato
Shade variation

V1 base bianco, riquadri bianco

V3 base carta da zucchero, grigio chiaro, grigio medio, grigio scuro
riquadri carta da zucchero, grigio chiaro, grigio medio, grigio scuro

Imballi | Packing

ARTICOLO ITEM	FORMATO SIZE	SCATOLA BOX			PALLET PALLET			
		PZ	MQ	KG	BOX	PZ	MQ	KG
Base	13,2x26,6cm 5.2"x10.5"	28	1,00	15,00	50	1.400	50,00	770
Riquadri	13,2x26,6cm 5.2"x10.5"	28	1,00	15,00	50	1.400	50,00	770
Jolly	1,2x26,6cm 0.5"x10.5"	4	-	0,23				

Pezzi speciali | Special pieces

	bianco	GVS533L	● 04
	grigio chiaro	RQD501L	● 04
jolly	grigio medio	RQD502L	● 04
1,2x26,6cm	grigio scuro	RQD503L	● 04
0.5"x10.5"	carta da zucchero	GTD505L	● 04

Dimensioni | Sizing

Piastrelle non rettificate | Non-rectified tiles
Carreaux non rectifiés

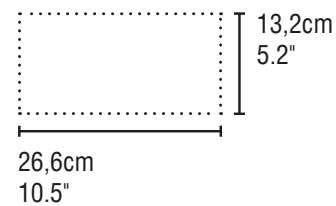
**Posa | Posa**

Istruzioni di posa per piastrelle con variazione cromatica:
si consiglia di prelevare le piastrelle da più scatole contemporaneamente
per garantire una corretta stonalizzazione che esalti la variabilità
e la casualità della superficie finita.

Lying instructions for tiles with colour variation:
it is recommended to take tiles from several boxes at a time
to ensure proper shade variation that enhances the variability
and randomness of the finished surface.

Il est recommandé de prélever des carreaux de plusieurs boîtes en même
temps pour garantir une pose plus homogène améliorant ainsi la variabilité
et le caractère aléatoire de la surface finie.

Colori NCS | NCS Colours

Bianco	NCS S 0300-N
Grigio Chiaro	NCS S 1002-Y
Grigio Medio	NCS S 2000-N
Grigio Scuro	NCS S 3502-Y
Carta Da Zucchero	NCS S 3010-B10G

Abbinamenti consigliati | Suggested combinations

3Lati, Confetti, Oltre, Genesi, Pigmento, Alchimia, Superfici20

Fuga | Joint

Fuga minima 2mm | Minimum joint 2mm
Joint d'au moins 2mm

Modularità | Modularity

La serie Riquadri è modulare per formato e gamma cromatica
con il rivestimento 3Lati.

The Riquadri collection is modular by format and color range
with 3Lati wall tile Collection.

La série Riquadri est modulable par format et couleur avec
la série 3Lati.

QC MORE +

Scansiona il QR per accedere
a info aggiuntive su:
- Colori NCS | Stucchi
- Caratteristiche tecniche



Scan the QR code to access
additional information on:
- Colour NCS | Grouts
- Technical characteristics

Scanne le QR code
pour accéder aux informations
successives sur:
- Couleurs NCS | Joints
- Les caractéristiques techniques

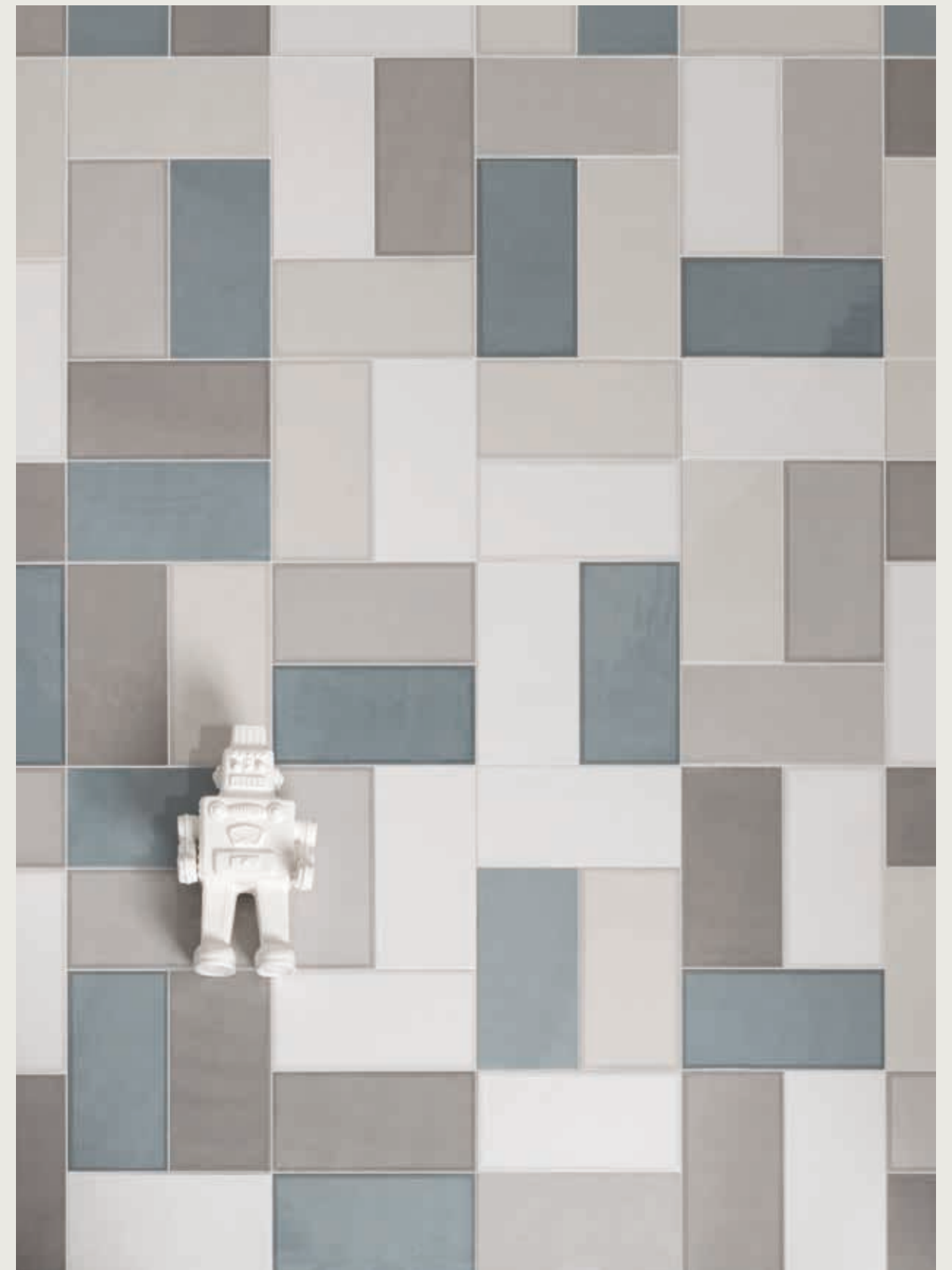

riquadri base bianco, grigio chiaro, grigio medio, grigio scuro, carta da zucchero
riquadri bianco, grigio chiaro, grigio medio, grigio scuro, carta da zucchero

GENESI

Rivestimento in pasta bianca
White body wall tiles

Monocromatico
Monochromatic
V1

Matt/Lucido
Matt/Glossy

Materiale riciclato
Recycled Content
69%

6,5x26,6cm
2.5"x10.5"

6,5x13,2cm
2.5"x5.2"

13,2x40cm
5.2"x15.8"

13,2x13,2cm
5.2"x5.2"

6,5x40cm
2.5"x15.8"

9MM



Scopri di più
su Genesis
Discover more
about Genesis

Genesis è nascita, vita, origine del tutto. La collezione, culla dell'intero concetto di Quintessenza Ceramiche, presenta una raffinata scala monocromatica che, attraverso il giusto bilanciamento di tono, luminosità e saturazione, crea un effetto omogeneo e armonioso. Un altro punto forte di Genesis è la modularità tra i formati che permette di personalizzare la parete assecondando le più svariate esigenze progettuali. Inoltre, la struttura, leggermente mossata, ricorda le mattonelle fatte a mano.



genesis 6,5x26,6 acquamarina lucido
confetti bianco.cotto



Genesis means birth, life, and the origin of all things. This collection forms the basis for the entire Quintessenza Ceramiche concept. It offers a delicate monochrome scale which, through a perfect balancing of tone, brightness and colour intensity, creates a uniform, harmonious effect. Another advantage of Genesis is its modular formats that allow walls to be personalised, thereby satisfying a vast range of design requirements. Its slightly irregular structure is also reminiscent of handmade bricks.

Genesis est la naissance, la vie, l'origine de toute chose. La collection, berceau de tout le concept Quintessenza Ceramiche, présente une échelle monochromatique raffinée qui, grâce au juste équilibre de couleur, de luminosité et tonalité, crée un effet homogène et harmonieux. Un autre point fort de Genesis est la modularité entre les formats qui permet de personnaliser le mur pour s'adapter aux projets les plus variés. De plus, la structure légèrement ondulée rappelle un carrelage artisanal.



genesis 6,5x26,6 antracite lucido

genesis 6,5x13,2 bianco lucido,
cenere, antracite, perla



genesi 6,5x13,2 bianco lucido, carta da zucchero lucido, acquamarina lucido

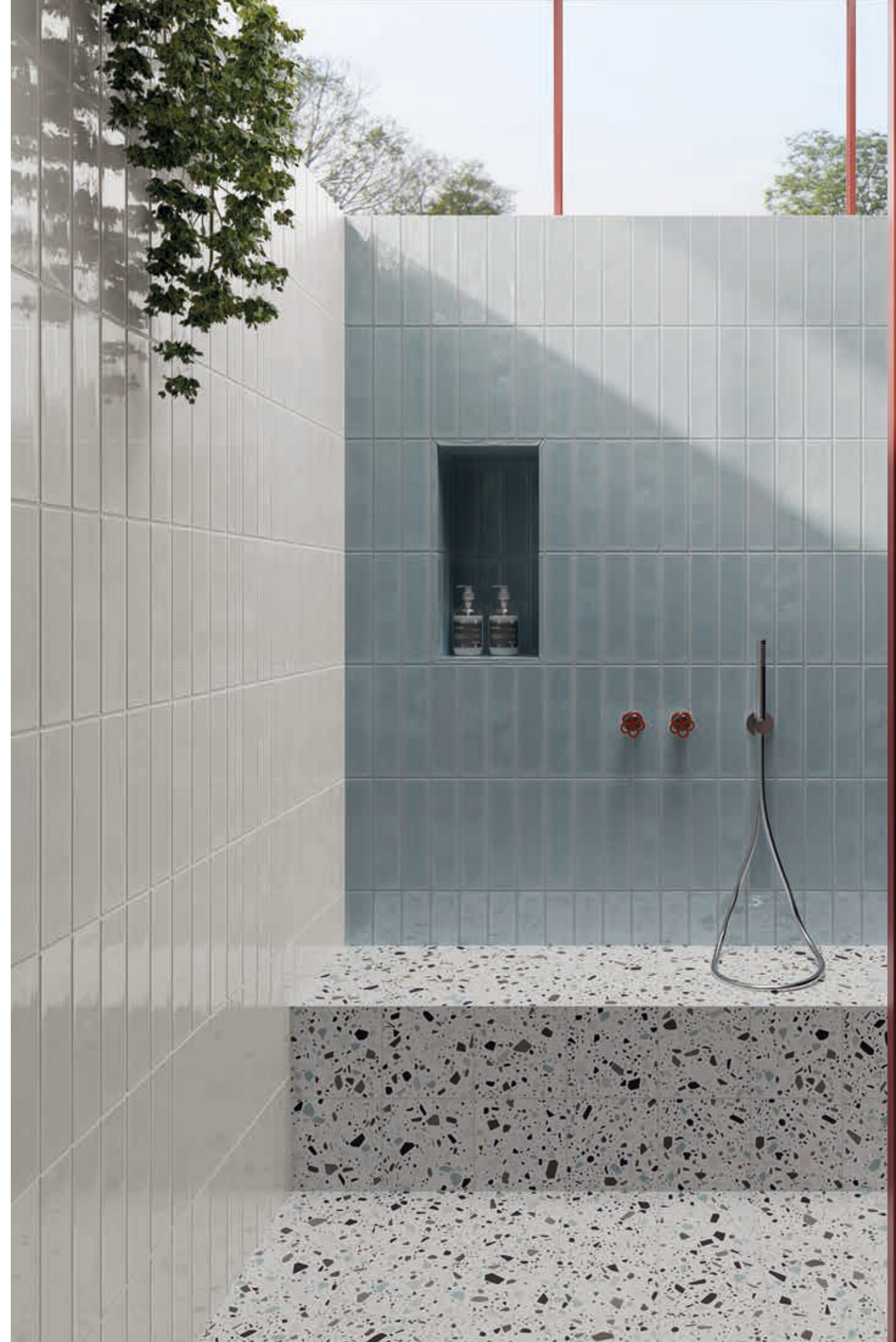

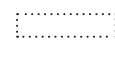

genesi 6,5x26,6 perla lucido, carta da zucchero lucido,
confetti bianco.petrolio

GENESI

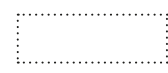
 6,5x26,6cm
2.5"x10.5"

 13,2x40cm
5.2"x15.8"

 6,5x13,2cm
2.5"x5.2"

 9MM

Rivestimento in pasta bianca
White body wall tiles

 Monocromatico
Monochromatic
V1

 Matt/Lucido
Matt/Glossy

 Materiale riciclato
Recycled Content
69%

BIANCO LUCIDO GVS105L ■ 02



13,2X13,2

BIANCO LUCIDO GTD101L ■ 06

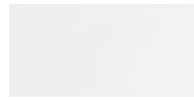

6,5X13,2

BIANCO MATT GTD110M ■ 06



6,5X13,2

BIANCO LUCIDO GVS113L ■ 02

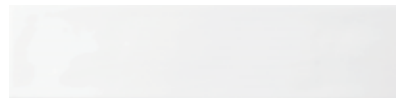

6,5X26,6

BIANCO MATT GVS109M ■ 02



6,5X26,6

BIANCO LUCIDO GQR104L ■ 07

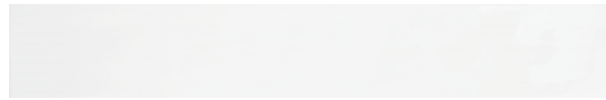

6,5X40

BIANCO MATT GQR101M ■ 07

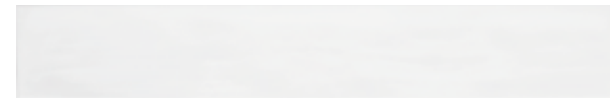

6,5X40

BIANCO LUCIDO GQR110L ■ 05

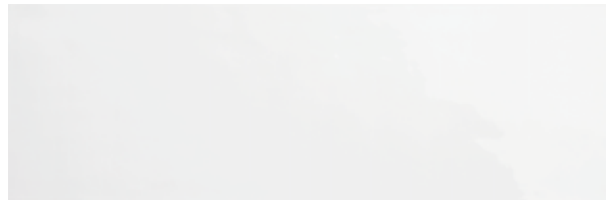

13,2X40

BIANCO MATT GQR107M ■ 05



13,2X40

GREIGE LUCIDO GVS115L ■ 02



6,5X26,6

GTD104L ■ 06



6,5X13,2

TORTORA LUCIDO GVS119L ■ 02



6,5X26,6

GTD105L ■ 06



6,5X13,2

CARTA DA ZUCCHERO LUCIDO GVS121L ■ 04



6,5X26,6

GTD107L ■ 07



6,5X13,2

ACQUAMARINA LUCIDO GVS120L ■ 04



6,5X26,6

GTD106L ■ 07



6,5X13,2

PERLA LUCIDO GVS117L ■ 02



6,5X26,6

GTD102L ■ 06



6,5X13,2

CENERE LUCIDO GVS118L ■ 02



6,5X26,6

GTD103L ■ 06



6,5X13,2

ANTRACITE LUCIDO GVS116L ■ 05



6,5X26,6

GTD108L ■ 08





6,5X13,2

Imballi | Packing

ARTICOLO ITEM	FORMATO SIZE	SCATOLA BOX			PALLET PALLET			
		PZ	MQ	KG	BOX	PZ	MQ	KG
Genesis	6,5x26,6cm 2.5"x10.5"	57	1,00	15,60	50	2.850	50,00	800
Genesis	6,5x13,2cm 2.5"x5.2"	58	0,50	7,79	95	5.510	47,50	760
Genesis	6,5x40cm 2.5"x15.8"	38	1,00	15,00	50	1.900	50,00	770
Genesis	13,2x40cm 5.2"x15.8"	19	1,00	15,60	50	950	50,00	800
Genesis	13,2x13,2cm 5.2"x5.2"	57	1,00	15,60	50	2.850	50,00	800
Jolly	1.2x26,6cm 0.5"x10.5"	4	-	0,23				
Bullnose Lineare	6,5x26,6cm 2.5"x10.5"	57	-	14,40				

Pezzi speciali | Special pieces

 jolly 1,2x26,6cm 0.5"x10.5"	bianco matt	GVS549M ● 04	 bianco lucido GVS505L ● 04
	bianco lucido	GVS533L ● 04	
	greige lucido	GVS535L ● 04	
	antracite lucido	GVS536L ● 04	
	perla lucido	GTD501L ● 04	
	cenere lucido	GTD502L ● 04	
	tortora lucido	GTD503L ● 04	
	acquamarina lucido	GTD504L ● 04	
	carta da zucchero lucido	GTD505L ● 04	

Dimensioni | Sizing

Piastrelle non rettificate | Non-rectified tiles
Carreaux non rectifiés

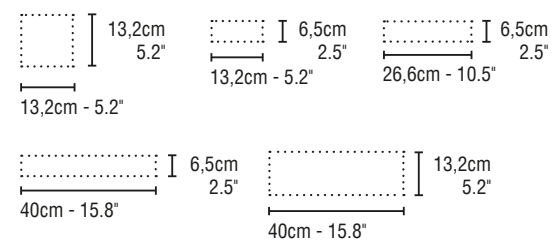

Colori NCS | NCS Colours

Bianco Luc./Matt	NCS S 0300-N
Perla	NCS S 1502-Y50R
Cenere	NCS S 3500-N
Acquamarina	NCS S 2002-G50Y
Carta Da Zucchero	NCS S 3010-B10G
Antracite	NCS S 8502-B
Tortora	NCS S 3005-Y20R
Greige	NCS S 1505-Y20R

Fuga | Joint

Fuga minima 2mm | Minimum joint 2mm
Joint d'au moins 2mm

QC MORE ⁺

Scansiona il QR per accedere
a info aggiuntive su:
- Colori NCS | Stucchi
- Caratteristiche tecniche



Scan the QR code to access
additional information on:
- Colour NCS | Grouts
- Technical characteristics

Scanne le QR code
pour accéder aux informations
successives sur:
- Couleurs NCS | Joints
- Les caractéristiques techniques

Abbinamenti consigliati | Suggested combinations

Pigmento, Pigmento10, Confetti, Minima8.6, Alchimia, Superfici20, Oltre, 3Lati, Riquadri



genesis 6,5x26,6 bianco lucido
greige lucido, perla lucido, acquamarina lucido

CROMIA26

Rivestimento in pasta bianca
White body wall tiles

Monocromatico
Monochromatic
V1

Lucido
Glossy

Materiale riciclato
Recycled Content
69%

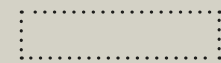

6,5x26,6CM
2.5"x10.5"

9MM



Scopri di più
su Cromia26
Discover more
about Cromia26



Cromia26 è l'elegante trionfo della scala cromatica che dona al formato 6,5x26,6cm una cadenza perfetta di nuance calde e fredde. Un'ampia gamma colori che consente grande versatilità al prodotto, esaltata da una superficie leggermente concava e da una struttura lavorata a bassorilievo. I toni ricercati donano a Cromia26 un carattere poetico e contemporaneo con le cadenze di colori in beige, grigio, verde e metallizzato nelle sue tre sfumature oro, bronzo e acciaio che regalano un tocco vintage a tutta la collezione.



cromia26 grigio5 , grigio4 , grigio3 , grigio2



Cromia26 is the elegant colour scale which makes the 6.5x26.6cm size the perfect solution for both cold and warm compositions. A vast range of colours which provides high versatility, enhanced by a subtly convex surface decorated in a bas relief finish. Its elegant tonalities make Cromia26 a poetic, contemporary collection: tones of beige, grey, green are supplemented by the vintage tones of metallized gold, bronze and steel.

Cromia26 est le triomphe élégant de la gamme chromatique qui confère au format 6,5x26,6cm une cadence parfaite de nuances chaudes et froides. Une large gamme de couleurs qui permet une grande polyvalence au produit, renforcée par une surface légèrement concave et une structure travaillée en bas-relief. Les tons raffinés confèrent à Cromia26 un caractère poétique et contemporain avec les cadences de couleurs beige, gris, vert et métallisé dans ses trois nuances d'or, bronze et acier qui donnent une touche vintage à l'ensemble de la collection.

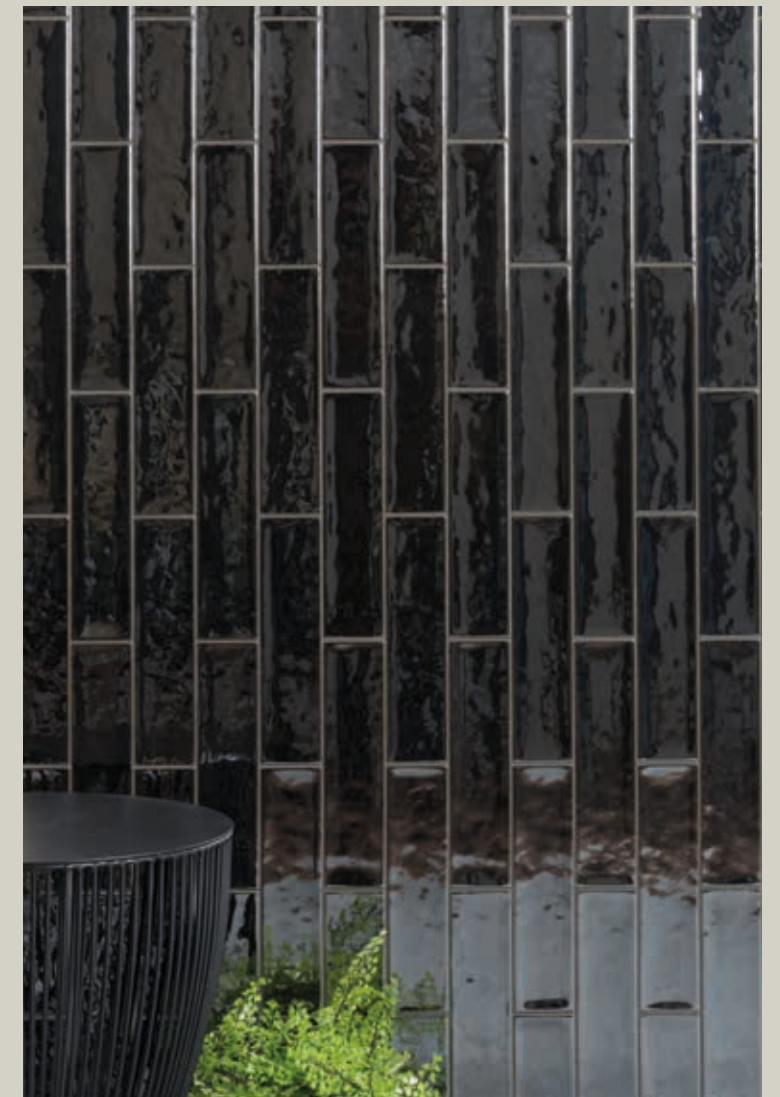

cromia26 oro

cromia26 acciaio

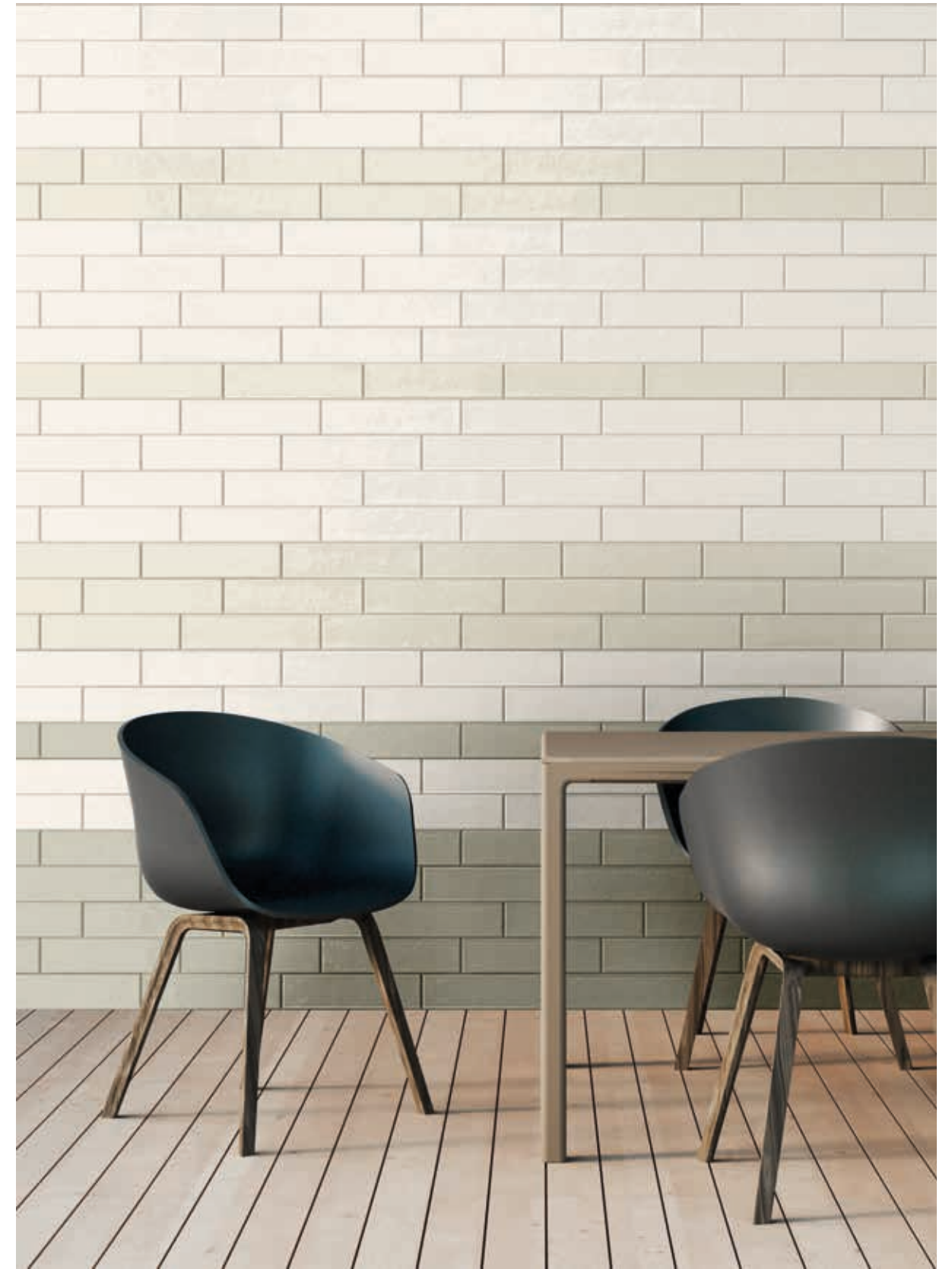

cromia26 beige1, beige2, beige3

cromia26 beige1, verde1, verde2

CROMIA26

6,5x26,6cm
2.5"x10.5"

9MM

Rivestimento in pasta bianca
White body wall tiles

V1
Monocromatico
Monochromatic

Lucido
Glossy

69%
Materiale riciclato
Recycled Content

BIANCO LUCIDO CRV106L ■ 02



GRIGIO1 LUCIDO CRV101L ■ 02



GRIGIO2 LUCIDO CRV102L ■ 02



GRIGIO3 LUCIDO CRV103L ■ 02



GRIGIO4 LUCIDO CRV104L ■ 02



GRIGIO5 LUCIDO CRV105L ■ 05



ACCIAIO ■ 14



BEIGE1 LUCIDO CRV107L ■ 02



BEIGE2 LUCIDO CRV108L ■ 02



BEIGE3 LUCIDO CRV109L ■ 02



VERDE1 LUCIDO CRV110L ■ 02



VERDE2 LUCIDO CRV111L ■ 02



BRONZO ■ 14



ORO ■ 14



cromia26 bronzo

ATTENZIONE - PIASTRELLE CON COLORI METALLICI: I colori metallizzati sono realizzati con smalti speciali che tendono ad avere un effetto crackle naturale e una bassa resistenza a prodotti acidi ed alcalini. Non utilizzare prodotti di pulizia aggressivi, come candeggina e ammoniaca. Consultare la guida per l'installazione e la manutenzione a pag. 242



WARNING - TILES WITH METALLIC COLORS: Metallic colors are made with special glazes that tends to have a natural crackle effect and low resistance to acidic and alkaline cleaning products. Do not use aggressive cleaning products, such as bleach or ammonia. Check the installation and maintenance guide on page. 244

ATTENTION - CARREAUX AVEC ÉMAUX MÉTALLIQUES: les couleurs métallisées sont réalisées avec des émaux spéciaux qui tendent à avoir un effet craquelé naturel et une basse résistance aux produits acides et alcalins. Ne pas utiliser de produits agressifs pour le nettoyage comme l'eau de javel ou l'ammoniaque. Consultez les conseils d'instructions de pose et d'entretien page 246

Imballi | Packing

ARTICOLO ITEM	FORMATO SIZE	SCATOLA BOX			PALLET PALLET			
		PZ	MQ	KG	BOX	PZ	MQ	KG
Cromia26	6,5x26,6cm 2.5"x10.5"	57	1,00	15,00	50	2.850	50,00	770
Bullnose lineare	6,5x26,6cm 2.5"x10.5"	57	/	14,40				
Jolly	1,2x26,6cm 0.5"x10.5"	4	/	0,23				

Pezzi speciali | Special pieces

 jolly 1,2x26,6cm 0.5"x10.5"	bianco lucido	GVS533L ●04	 bullnose lineare 6,5x26,6cm 2.5"x10.5"	bianco lucido	CRV506L ●01
	grigio1 lucido	GTD501L ●04		grigio1 lucido	CRV501L ●01
	grigio2 lucido	GTD502L ●04		grigio2 lucido	CRV502L ●01
	grigio3 lucido	CRV513L ●04		grigio3 lucido	CRV503L ●01
	grigio4 lucido	CRV514L ●04		grigio4 lucido	CRV504L ●01
	grigio5 lucido	CRV515L ●04		grigio5 lucido	CRV505L ●01
	beige1 lucido	CRV533L ●04		beige2 lucido	CRV520L ●01
	beige2 lucido	CRV534L ●04		beige3 lucido	CRV521L ●01
	beige3 lucido	CRV535L ●04		verde1 lucido	CRV522L ●01
	verde1 lucido	CRV536L ●04		verde2 lucido	CRV523L ●01
	verde2 lucido	CRV537L ●04		oro	CRV524L ●05
				bronzo	CRV525L ●05
				acciaio	CRV549L ●05

Dimensioni | Sizing

Piastrelle non rettificate | Non-rectified tiles
Carreaux non rectifiés

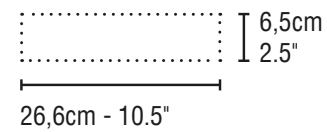
**Colori NCS | NCS Colours**

Bianco	NCS S 0300-N
Grigio 1	NCS S 1502-Y
Grigio 2	NCS S 2500-N
Grigio 3	NCS S 4502-Y
Grigio 4	NCS S 6502-Y
Grigio 5	NCS S 8000-N
Beige 1	NCS S 1002-Y
Beige 2	NCS S 2005-Y30R
Beige 3	NCS S 3010 -Y20R
Verde 1	NCS S 2005-G80Y
Verde 2	NCS S 3010-G80Y

Fuga | Joint

Fuga minima 2mm | Minimum joint 2mm
Joint d'au moins 2mm

QC MORE +

Scansiona il QR per accedere
a info aggiuntive su:
- Colori NCS | Stucchi
- Caratteristiche tecniche



Scan the QR code to access
additional information on:
- Colour NCS | Grouts
- Technical characteristics

Scanne le QR code
pour accéder aux informations
successives sur :
- Couleurs NCS | Joints
- Les caractéristiques techniques

Abbinamenti consigliati | Suggested combinations

Superfici20, Pigmento, Pigmento10, Minima8.6, Oltre, Alchimia, Confetti

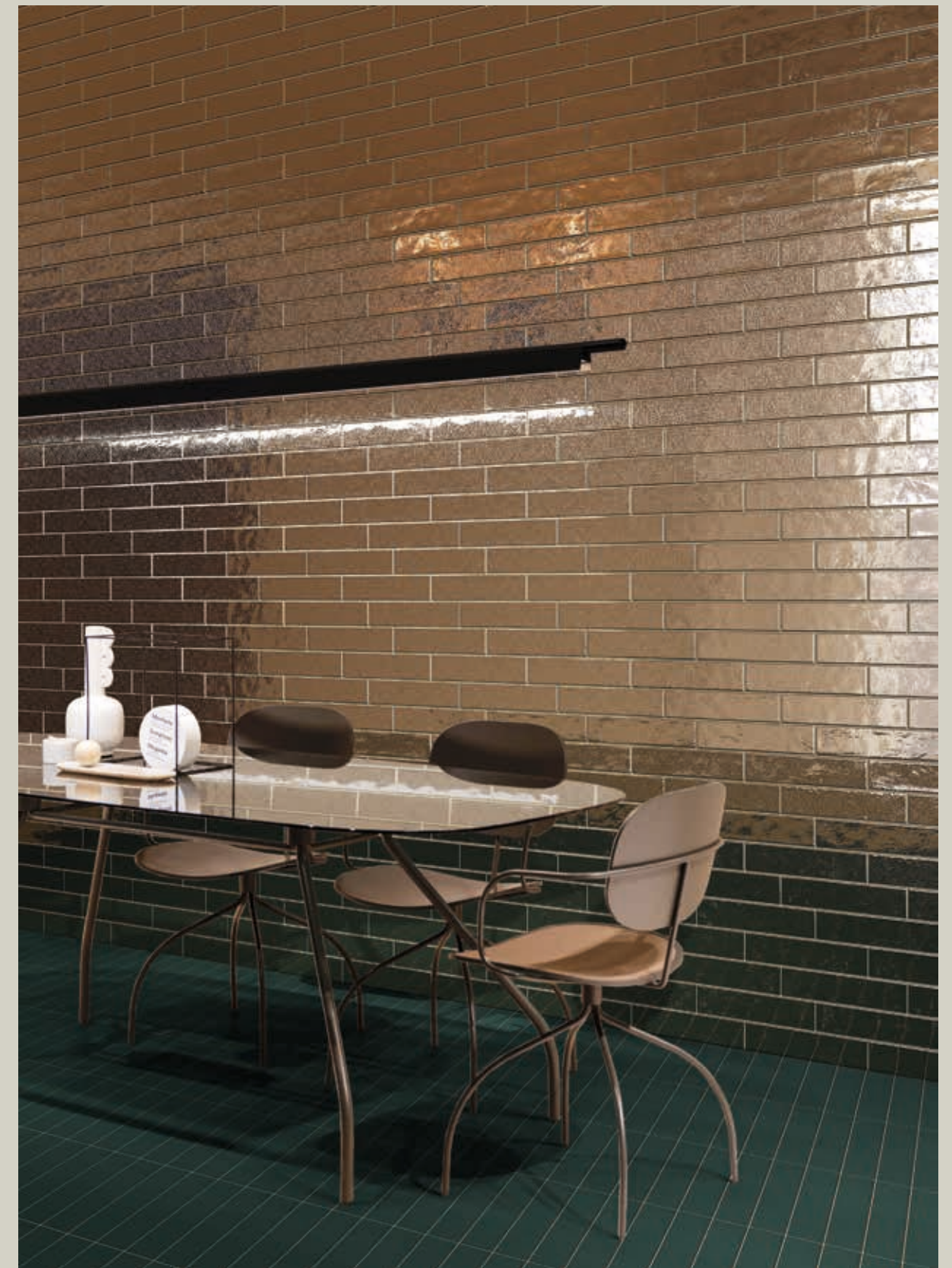

cromia26 oro
modulo base muschio

SFUMATURE

Rivestimento in pasta bianca
White body wall tiles

Stonalizzato
Shade variation
V3

Lucido
Glossy

Materiale riciclato
Recycled Content
34%

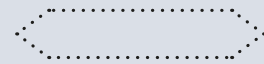

6,5x33CM
2.5"x13"

9MM



Scopri di più
su Sfumature
Discover more
about Sfumature



La forza cromatica delle nuances trova nella collezione Sfumature una varietà grafica in grado di dar vita a rivestimenti funzionali e creativi. Due sono le finiture presentate nell'innovativo formato 6,5x33cm a losanga con sei colori sfumati lucidi (bianco, grigio perla, fango, verde, azzurro, cipria). La prima riprende la struttura della collezione Genesis, la seconda chiamata Effetti, offre un mix di 9 strutture, dagli effetti spatolati a una moltitudine decorata di rilievi grafici, che creano un movimento unico per la creatività.



sfumature azzurro, bianco, effetti grigio perla

The chromatic potential of nuances in the Sfumature collection is expressed in an extraordinary level of graphic diversity that's ideal to create functional and original surfaces. There are two finishes in the innovative 6.5x33cm lozenge, with six shaded gloss colours (bianco, grigio, fango, verde, azzurro, cipria). The first finish is reminiscent of the texture of the Genesi collection with its exquisite handcrafted effect. Called Effetti, the second finish offers a mix of 9 textures, from brushed surfaces to multiple decorated graphic reliefs that offer exceptional dynamics for creative interpretation.

La force chromatique des nuances trouve dans la collection Sfumature une variété graphique capable de donner vie à des revêtements fonctionnels et créatifs. Deux finitions sont présentées dans le format innovant losange 6,5x33cm avec six couleurs nuancées brillantes (blanc, gris perle, taupe, vert, bleu clair, rose poudré). La première reprend la structure de la collection Genesi, la seconde baptisée Effets, propose un mélange de 9 structures, des effets de spatule à une multitude décorée de reliefs graphiques, qui créent un mouvement unique de créativité.

sfumature cipria, fango, grigio perla, effetti fango



sfumature verde, azzurro, effetti verde, effetti azzurro



sfumature bianco, azzurro, effetti grigio perla



sfumature effetti cipria

SFUMATURE

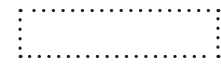

6,5x33cm
2.5"x13"

9MM

Rivestimento in pasta bianca
White body wall tiles

Stonalizzato
Shade variation
V3

Lucido
Glossy

Materiale riciclato
Recycled Content
34%

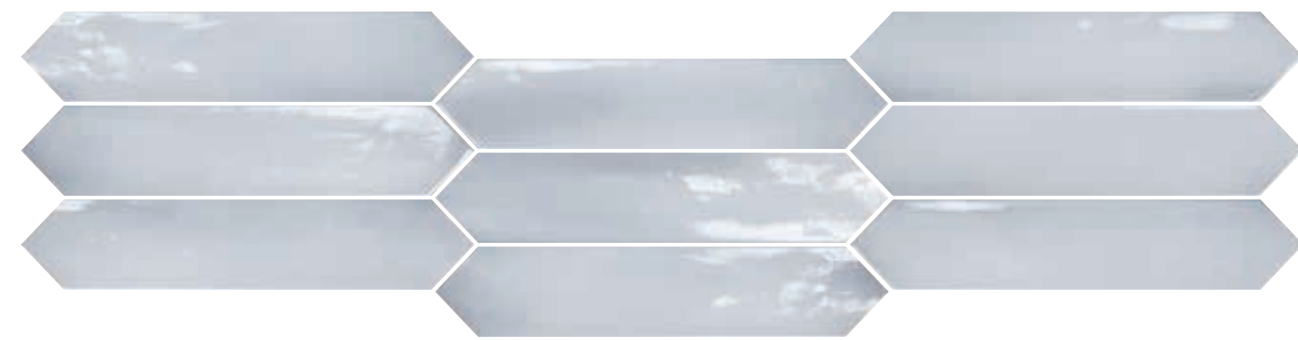
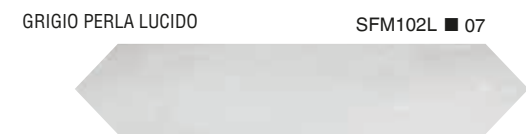
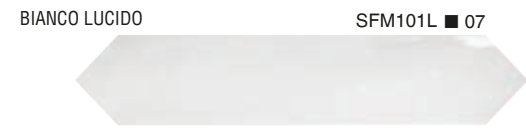

Schema di posa
Laying pattern

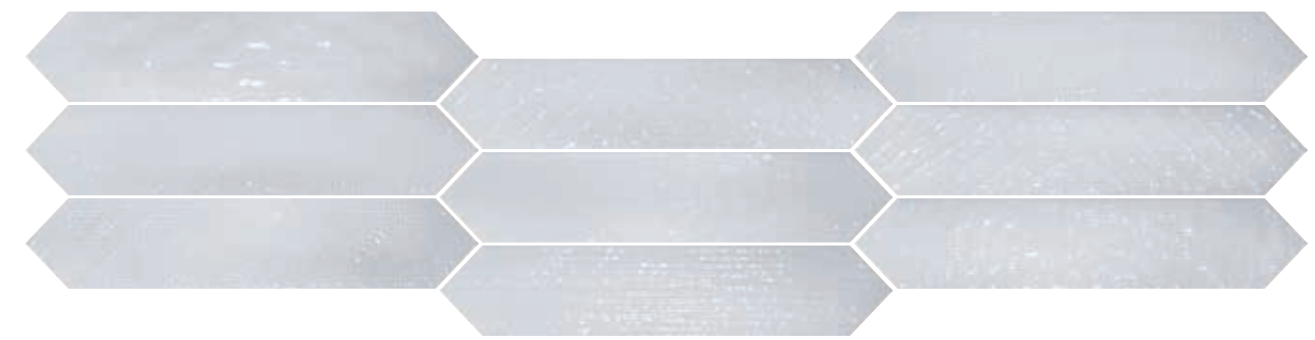

Schema di posa
Laying pattern

*Articoli composti da 9 strutture confezionate casualmente all'interno della stessa scatola.
*Items made up of 9 different structures, randomly packed in the same box.
*Articles composés de 9 différents patrons et mélangés à l'intérieur de chaque boîte.

Imballi | Packing

ARTICOLO ITEM	FORMATO SIZE	SCATOLA BOX			PALLET PALLET			
		PZ	MQ	KG	BOX	PZ	MQ	KG
Sfumature	6,5x33cm 2.5"x13"	52	1,00	14,80	50	2.600	50,00	760
Effetti	6,5x33cm 2.5"x13"	52	1,00	15,20	50	2.600	50,00	780
Jolly	1,2x26,6cm 0,5"x10,5"	4	/	0,23				

Pezzi speciali | Special pieces

	bianco lucido	GVS533L	● 04
	grigio perla lucido	SFM501L	● 04
	fango lucido	SFM502L	● 04
	verde lucido	SFM503L	● 04
	azzurro lucido	SFM504L	● 04
	cipria lucido	SFM505L	● 04
jolly 1,2x26,6cm 0,5"x10,5"			

Dimensioni | Sizing

Piastrelle non rettificate | Non-rectified tiles
Carreaux non rectifiés

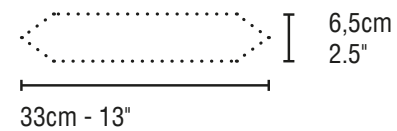
**Fuga | Joint**

Fuga minima 2mm | Minimum joint 2mm
Joint d'au moins 2mm

Colori NCS | NCS Colours

Bianco	NCS S 0502-G
Perla	NCS S 1502-G
Fango	NCS S 2500-N
Verde	NCS S 3010-B90G
Azzurro	NCS S 3010-B50G
Cipria	NCS S 3005-Y80R

QC MORE +

Scansiona il QR per accedere
a info aggiuntive su:
- Colori NCS | Stucchi
- Caratteristiche tecniche



Scan the QR code to access
additional information on:
- Colour NCS | Grouts
- Technical characteristics

Scanne le QR code
pour accéder aux informations
successives sur :
- Couleurs NCS | Joints
- Les caractéristiques techniques

Abbinamenti consigliati | Suggested combinations

Oltre, Confetti, Pigmento, Alchimia

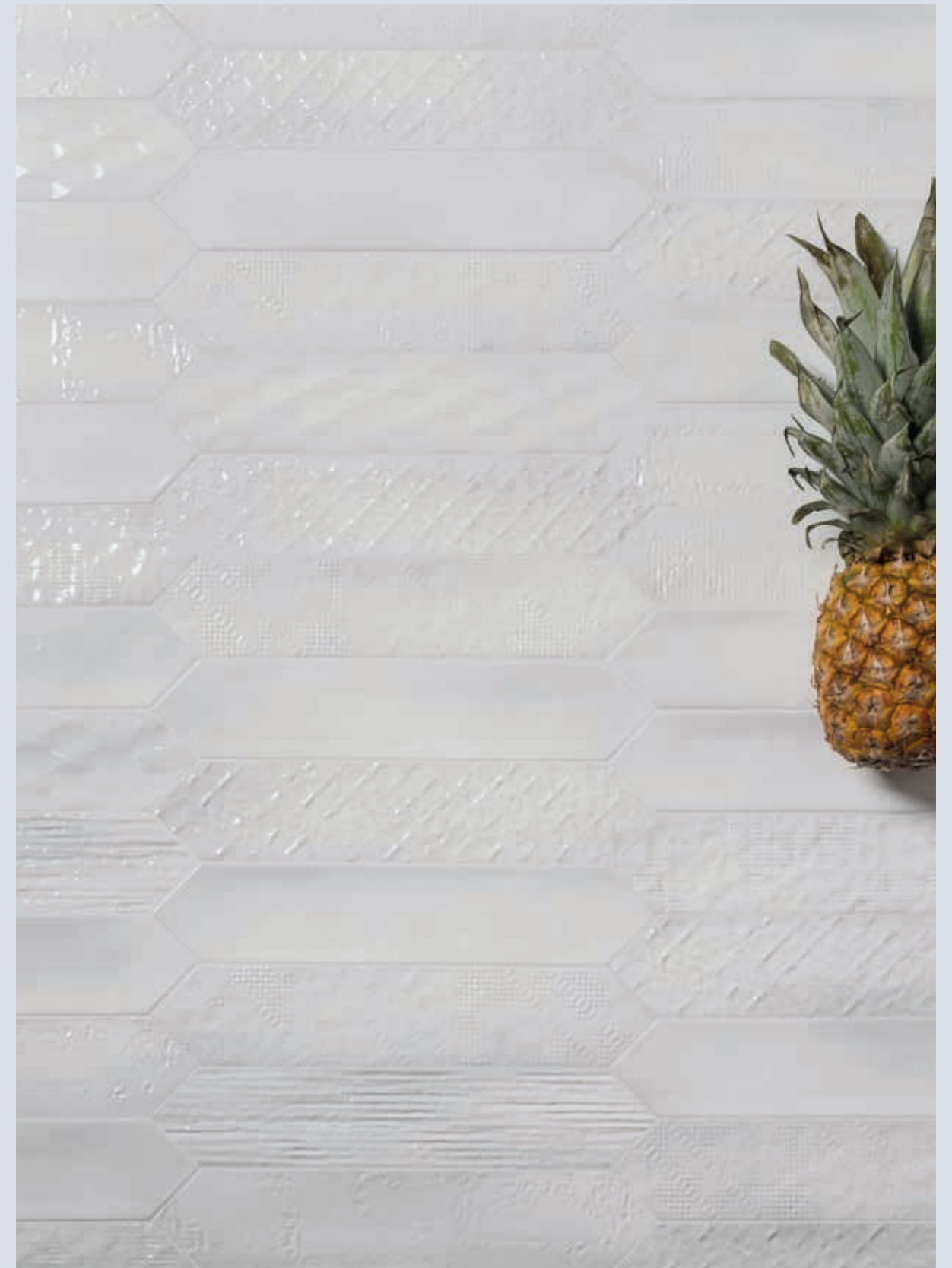

sfumature effetti bianco

PORTICCIOLO

Rivestimento in pasta bianca
White body wall tiles

Texture
Texture
V4

Matt
Matt

Materiale riciclato
Recycled Content
61%



5x25CM
2"x10"



9MM



Scopri di più
su Porticciolo
Discover more
about Porticciolo

Il fascino del legno usurato. La collezione Porticciolo di Quintessenza Ceramiche esalta la bellezza delle imperfezioni per una piastrella dall'aspetto vissuto. Come piccole pennellate, le diverse colorazioni del legno, ora stonalizzato ora graffiato, disegnano un affascinante quadro pittorico. Segni grafici e venature naturali per superfici che richiamano i legni degli stabilimenti balneari decorati dalla salsedine e dal mare. Un mood sorprendente per uno stile trasversale grazie alle sfumature brezza di mare e brezza di terra.



porticciolo brezza di mare

The charm of worn wood. Quintessenza Ceramiche's Porticciolo collection evokes the beauty of imperfection in a series of tiles with an aged aesthetic. The colours of wood, with shading and scratch effects, act like small brush strokes to create a fascinating painterly effect. The markings and natural veining of wood evoke seaside bathing establishments, decorated by their exposure to the sun and sea. The result is an unexpected style characterised by the Brezza di Mare and Brezza di Terra.

Le charme du bois usé. La collection Porticciolo de Quintessenza Ceramiche rehausse la beauté des imperfections pour un carrelage à l'aspect usé. Tels de petits coups de pinceau, les différentes couleurs du bois, tantôt ombrées, tantôt grattées, dressent un fascinant tableau pictural. Des signes graphiques et des grains naturels pour des surfaces qui rappellent les bois des établissements balnéaires décorés par le sel et la mer. Une ambiance surprenante pour un style transversal grâce aux nuances brezza di mare et brezza di terra.



porticciolo brezza di terra

porticciolo brezza di terra

PORTICCIOLO

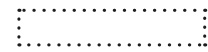

5x25cm
2"x10"

9MM

Rivestimento in pasta bianca
White body wall tiles

Texture
Texture
V4

Matt
Matt

Materiale riciclato
Recycled Content
61%

BREZZA DI MARE*

PRT106M ■ 09



BREZZA DI TERRA*

PRT107M ■ 09



*Articoli composti da 18 grafiche confezionati casualmente all'interno della stessa scatola.
*Items made up of 18 patterns, randomly packed in the same box.
*Articles composés de 18 différents patrons et mélangés à l'intérieur de chaque boîte.

Imballi | Packing

ARTICOLO ITEM	FORMATO SIZE	SCATOLA BOX			PALLET PALLET			
		PZ	MQ	KG	BOX	PZ	MQ	KG
Brezza di mare	5x25cm 2"x10"	40	0,50	7,78	90	3.600	45	720
Brezza di terra	5x25cm 2"x10"	40	0,50	7,78	90	3.600	45	720
Jolly	1,2x25cm 0.5"x10"	4	/	0,23				

Pezzi speciali | Special pieces

	Brezza di mare	PRT506M ● 13
	Brezza di terra	PRT513M ● 13
jolly		
1,2x25cm		
0.5"x10"		

Dimensioni | Sizing

Piastrelle non rettificate | Non-rectified tiles
Carreaux non rectifiés

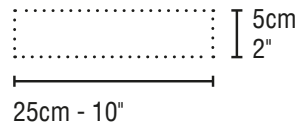

Fuga | Joint

Fuga minima 2mm | Minimum joint 2mm
Joint d'au moins 2mm

QC MORE +

Scansiona il QR per accedere a info aggiuntive su:
- Colori NCS | Stucchi
- Caratteristiche tecniche



Scan the QR code to access additional information on:
- Colour NCS | Grouts
- Technical characteristics

Scanne le QR code pour accéder aux informations successives sur:
- Couleurs NCS | Joints
- Les caractéristiques techniques

Abbinamenti consigliati | Suggested combinations

Confetti, Pigmento, Pigmento10, Minima8.6, Superfici20, Alchimia, Oltre



porticciolo brezza di mare

ALCHIMIA

Gres porcellanato
Porcelain stoneware

Monocromatic\Texture
Monochromatic\Texture
V1/V4

Matt
Matt

Materiale riciclato
Recycled Content
43%



26,6x23CM
10.5"x9"

9MM



Scopri di più
su Alchimia
Discover more
about Alchimia

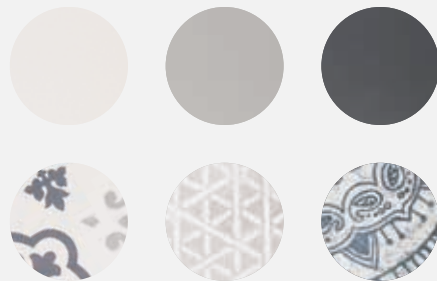

Nell'antichità, uno dei più ardui obiettivi degli Alchimisti era rappresentato dalla ricerca della Pietra Filosofale o Quintessenza, il principio capace di rivelare i segreti dell'esistenza e della materia, come l'elisir di lunga vita o la trasmutazione dei metalli in oro.

Attraverso l'alternanza di diversi esagoni la ceramica di Alchimia cambia forma e geometria, diventando armonia decorativa con trame arabesche e patchwork o cangiando in un'illusione di forme, dimensioni e profondità ottenuta con l'equilibrio dei colori.





In ancient times one of the biggest challenges facing the Alchemists was the search for the Philosopher's Stone or the Quintessence, the element capable of revealing the secrets of life and matter, like the elixir of longevity or the transmutation of common metals into gold. Through the alternation of several hexagons, a surface created using the Alchimia collection offers changing shapes and geometry to create decorative harmony with arabesque and patchwork motifs or shifting towards an illusion of shapes, dimensions and depths obtained by the balanced use of colour.

Dans l'Antiquité, l'un des objectifs les plus ardues des Alchimistes était représenté par la recherche de la Pierre Philosophale ou Quintessence, principe capable de révéler les secrets de l'existence et de la matière, comme l'élixir de longue vie ou la transmutation des métaux en or. Par l'alternance de différents hexagones, les carrelages Alchimia changent de forme et de géométrie, devenant une harmonie décorative avec des textures arabesques et patchwork ou se transformant en une illusion de formes, de dimensions et de profondeur obtenue avec l'équilibre des couleurs.



alchimia elisir
genesi 6,5x26,5 bianco lucido



alchimia ars mix1,
modulo base mattone

alchimia ars mix2

ALCHIMIA

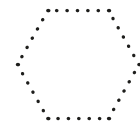

26,6x23CM
10.5"x9"

9MM

Gres porcellanato
Porcelain stoneware

V1/V4

Monocromatico\Texture
Monochromatic\Texture

Matt
Matt

43%

Materiale riciclato
Recycled Content

BIANCO MATT ALC101M ■ 11



ELISIR ALC109M ■ 15



ARS MIX1* ALC107M ■ 15



ARS MIX2* ALC108M ■ 15



GRIGIO MATT ALC102M ■ 11



Schema di posa
Laying pattern

NERO MATT ALC103M ■ 13



Stonalizzato
Shade variation

V1 bianco, grigio, nero, elisir

V4 ars mix1, ars mix2

*Articoli composti da 6 grafiche confezionati casualmente all'interno della stessa scatola.
*Items made up of 6 patterns, randomly packed in the same box.
*Articles composés de 6 différents patrons et mélangés à l'intérieur de chaque boîte.

Imballi | Packing

ARTICOLO ITEM	FORMATO SIZE	SCATOLA BOX			PALLET PALLET			
		PZ	MQ	KG	BOX	PZ	MQ	KG
Alchimia	26,6x23cm 10.5"x9"	11	0,50	9,80	84	924	42	843
Elisir	26,6x23cm 10.5"x9"	11	0,50	9,80	84	924	42	843
Ars mix	26,6x23cm 10.5"x9"	11	0,50	9,80	84	924	42	843

Dimensioni | Sizing

Piastrelle non rettificate soggette a lievi differenze di calibro.
Non-rectified tiles subject to slight differences in calibre.
Carreaux non rectifiés pouvant comporter de légères différences de calibre.

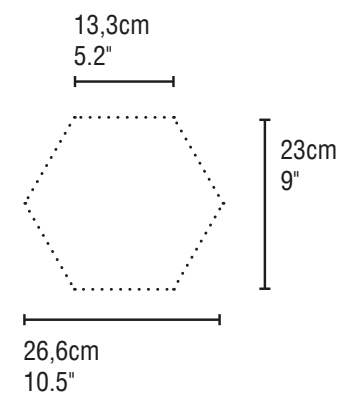
**Colori NCS | NCS Colours**

Nero	NCS S 7000-N
Bianco	NCS S 1500-N
Grigio	NCS S 2502-Y

Fuga | Joint

Fuga minima 2mm. Compensare differenze di calibro con la fuga.
Minimum 2mm joint. Compensate for differences in caliber with the joint.
Joint d'au moins 2mm. Compenser les différences de calibre avec le joint.

QC MORE +

Scansiona il QR per accedere a info aggiuntive su:
- Colori NCS | Stucchi
- Caratteristiche tecniche



Scan the QR code to access additional information on:
- Colour NCS | Grouts
- Technical characteristics

Scanne le QR code pour accéder aux informations successives sur:
- Couleurs NCS | Joints
- Les caractéristiques techniques

Abbinamenti consigliati | Suggested combinations

3lati, Pigmento, Pigmento10, Marea, Sfumature, Riquadri, Genesi, Modulo, Cromia26, Porticciolo, Tinte, Färgblock, Porticciolo



alchimia ars mix1, ars mix2

SUPERFICI 20

Gres porcellanato
Porcelain stoneware

Stonizzato
Shade variation
V2/V3/V4

Matt
Matt

Materiale riciclato
Recycled Content
43%



20x20cm
8"x8"

10MM



Scopri di più
su Superfici20
Discover more
about Superfici20

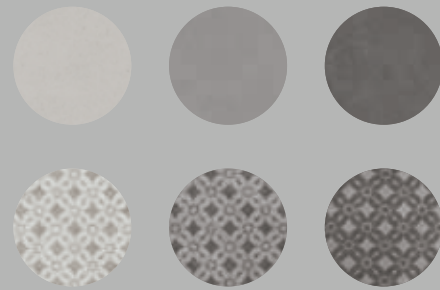

Roccia, Cemento, Slate e Riga: Quintessenza interpreta con Superfici20 alcune delle estetiche più iconiche dell'interior design e dell'architettura con una collezione eclettica e articolata in grado di creare una moltitudine di pose e applicazioni. 4 diverse strutture declinate in 3 colori, ognuno in 4 varianti cromatiche, rettificati e monocalibro capaci di vestire con libertà e stile gli spazi abitativi residenziali e commerciali.





Roccia, Cemento, Slate and Riga: with Superfici20, Quintessenza interprets some of the most iconic styles of interior design and architecture, thanks to an eclectic and comprehensive collection that offers a multitude of laying patterns and applications. 4 different, rectified and monocaliber structures in 3 colours, each with 4 tone variants, for decorating residential and retail living spaces with style and freedom.

Roccia, Cemento, Slate et Riga: Quintessenza interprète certaines des esthétiques intérieures les plus emblématiques avec Superfici20 design et architecture avec une collection éclectique et variée capable de créer une multitude de poses et d'applications. 4 finitions différentes disponibles en 3 couleurs, chacune en 4 variations chromatiques, rectifiées et monocalibres capables d'habiller les espaces de vie résidentiels et commerciaux avec liberté et style.



superfici20 riga antracite, slate grigio, slate perla, decoro tracce3 mix slate grigio

superfici20 riga perla, cemento perla, roccia perla, slate perla decoro tracce1 mix perla, decoro tracce2 mix perla, decoro tracce3 mix perla, riga grigio



superfici20 grigio cemento, riga perla

superfici20 fiore perla

SUPERFICI20



20x20cm
8"x8"

10MM

Gres porcellanato
Porcelain stoneware

Stonalizzato
Shade variation

V2/V3/V4

Matt
Matt

Materiale riciclato
Recycled Content

43%

PERLA

CEMENTO SVN108M ■ 07



SLATE SVN105M ■ 07

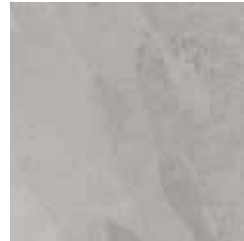

RIGA SVN106M ■ 07

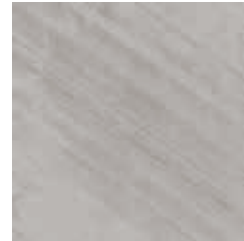

ROCCIA SVN107M ■ 07

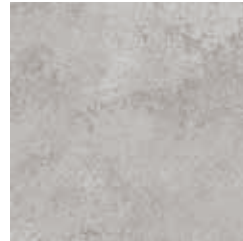

GRIGIO

CEMENTO SVN112M ■ 07



SLATE SVN109M ■ 07



RIGA SVN110M ■ 07

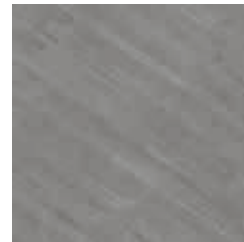

ROCCIA SVN111M ■ 07



ANTRACITE

CEMENTO SVN116M ■ 07

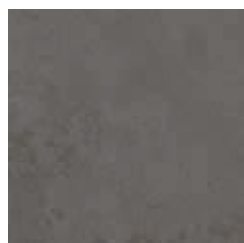

SLATE SVN113M ■ 07



RIGA SVN114M ■ 07

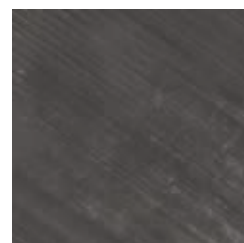

PERLA

FIORE SVN118M ■ 08

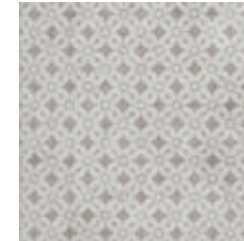

MOSAICO MIX SVN402M ■ 21



MURETTO MIX SVN406M ■ 22



4,7

4,7

2,3

20

GRIGIO

FIORE SVN119M ■ 08

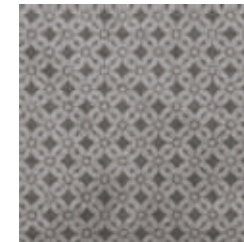

MOSAICO MIX SVN403M ■ 21



MURETTO MIX SVN407M ■ 22



4,7

4,7

2,3

20

ANTRACITE

FIORE SVN120M ■ 08



MOSAICO MIX SVN404M ■ 21

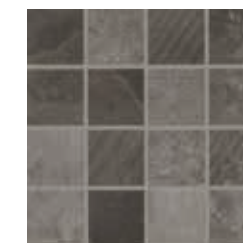

MURETTO MIX SVN408M ■ 22



4,7

4,7

2,3

20

Stonalizzato
Shade variation

V2 Cemento antracite, grigio, perla

V3 Roccia grigio, perla, Riga antracite, grigio, perla

V4 Slate antracite, grigio, perla

SUPERFICI20



20x20cm
8"x8"

10MM

Gres porcellanato
Porcelain stoneware

Stonalizzato
Shade variation

V2/V3/V4

Matt
Matt

Materiale riciclato
Recycled Content

43%

DECORO TRACCE1
MIX CEMENTO PERLA*

SVN310M ●13



DECORO TRACCE3
MIX SLATE PERLA*

SVN302M ●13

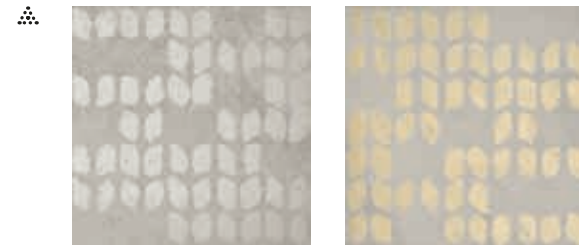

DECORO TRACCE2
MIX ROCCIA PERLA*

SVN306M ●13



DECORO TRACCE1
MIX CEMENTO GRIGIO*

SVN311M ●13

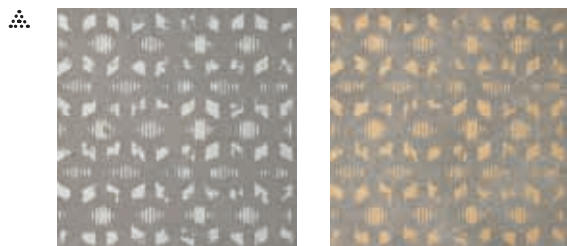

DECORO TRACCE3
MIX SLATE GRIGIO*

SVN303M ●13

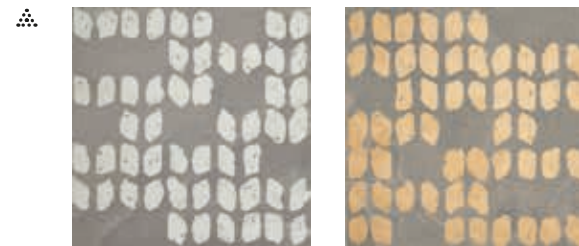

DECORO TRACCE2
MIX ROCCIA GRIGIO*

SVN307M ●13

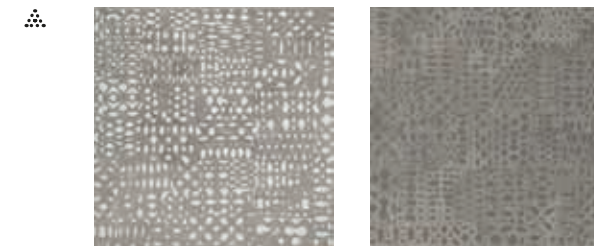

DECORO TRACCE1
MIX CEMENTO ANTRACITE*

SVN312M ●13

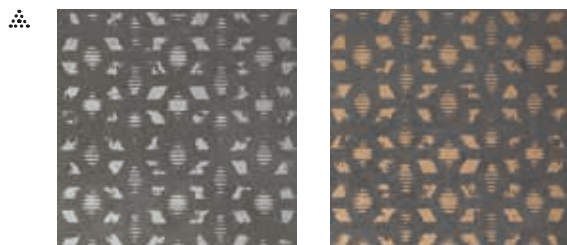

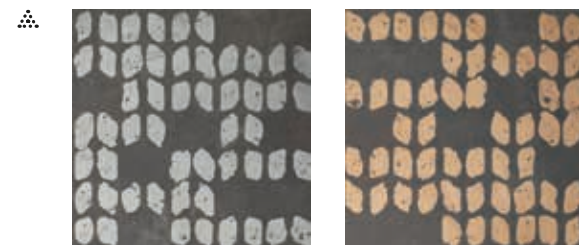

DECORO TRACCE3
MIX SLATE ANTRACITE*

SVN304M ●13



ATTENZIONE - PIASTRELLE CON COLORI METALLICI: 
I colori metallizzati sono realizzati con smalti speciali che tendono ad avere un effetto crackle naturale e una bassa resistenza a prodotti acidi ed alcalini. Non utilizzare prodotti di pulizia aggressivi, come candeggina e ammoniaca. Consultare la guida per l'installazione e la manutenzione a pag. 242

WARNING - TILES WITH METALLIC COLORS: 
Metallic colors are made with special glazes that tends to have a natural crackle effect and low resistance to acidic and alkaline cleaning products. Do not use aggressive cleaning products, such as bleach or ammonia. Check the installation and maintenance guide on page 244

ATTENTION - CARREAUX AVEC ÉMAUX MÉTALLIQUES: 
les couleurs métallisées sont réalisées avec des émaux spéciaux qui tendent à avoir un effet craquelé naturel et une basse résistance aux produits acides et alcalins. Ne pas utiliser de produits agressifs pour le nettoyage comme l'eau de javel ou l'ammoniaque. Consultez les conseils d'instructions de pose et d'entretien page 246

Stonalizzato
Shade variation

 V2 Cemento antracite, grigio, perla

 V3 Roccia grigio, perla, Riga antracite, grigio, perla

 V4 Slate antracite, grigio, perla

*Articoli composti da 2 grafiche confezionate casualmente all'interno della stessa scatola.
*Items made up of 2 different patterns, randomly packed in the same box.
*Articles composés de 2 différents patrons et mélangés à l'intérieur de chaque boîte.

Imballi | Packing

ARTICOLO ITEM	FORMATO SIZE	SCATOLA BOX			PALLET PALLET			
		PZ	MQ	KG	BOX	PZ	MQ	KG
Superfici20	20x20cm 8"x8"	24	0,96	20,74	54	1296	51,84	1140
Muretto	20x20cm 8"x8"	9	0,36	7,25	80	720	28,80	600
Mosaico	20x20cm 8"x8"	12	0,48	9,60	75	900	36,00	740
Decoro tracce mix	20x20cm 8"x8"	5	0,20	4,32				

Dimensioni | Sizing

Piastrelle rettificate | Rectified tiles
Carreaux rectifiés

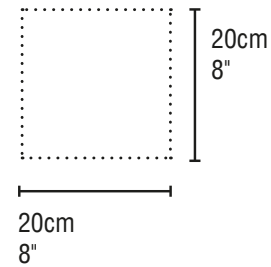

Colori NCS | NCS Colours

Perla	NCS S 3000-N
Grigio	NCS S 5502-Y
Antracite	NCS S 7500-N

Fuga | Joint

Fuga minima 2mm | Minimum joint 2mm
Joint d'au moins 2mm

QC MORE +

Scansiona il QR per accedere a info aggiuntive su:
- Colori NCS | Stucchi
- Caratteristiche tecniche



Scan the QR code to access additional information on:
- Colour NCS | Grouts
- Technical characteristics

Scanne le QR code pour accéder aux informations successives sur:
- Couleurs NCS | Joints
- Les caractéristiques techniques

Abbinamenti consigliati | Suggested combinations

3Lati, Cromia26, Genesi, Riquadri, Marea, Pigmento10, Pigmento, Modulo, Färgblock, Tinte, Sfumature



superfici20 fiore antracite, slate antracite

INFORMAZIONI
INFORMATIONS

233 PESI E IMBALLI
PACKING

234 CARATTERISTICHE TECNICHE
TECHNICAL FEATURES
CARACTERISTIQUES TECHNIQUES

239 CONDIZIONI GENERALI DI VENDITA
GENERAL TERMS AND CONDITIONS OF SALE
CONDITIONS GÉNÉRALES DE VENTE

242 ISTRUZIONI DI POSA E MANTENIMENTO
INSTALLATION AND MAINTENANCE GUIDE
INSTRUCTIONS DE POSE ET D'ENTRETIEN

248 CERTIFICAZIONI E SOSTENIBILITÀ AMBIENTALE
ENVIRONMENTAL SUSTAINABILITY AND CERTIFICATIONS
CERTIFICATIONS ET DURABILITÉ ENVIRONNEMENTALE

252 CREDITS

PESI E IMBALLI
PACKING

	Size Cm	Size Inch	Pcs. Box	M ² Box	Kg Box	Pcs. Pallet	Box pallet	M ² pallet	kg pallet
Alchimia	26,6x23	10.5"x9"	11	0,50	9,80	924	84	42	843
Elisir	26,6x23	10.5"x9"	11	0,50	9,80	924	84	42	843
Ars mix	26,6x23	10.5"x9"	11	0,50	9,80	924	84	42	843
3Lati	13,2x11,4	5.2"x4.5"	30	0,23	3,67	3.780	126	28,98	482
Confetti	18,6X18,6	7.3"x7.3"	13	0,45	8,30	1404	108	48,6	920
Cromia26	6,5x26,6	2.5"x10.5"	57	1,00	15,00	2.850	50	50,00	770
Bullnose Lineare	6,5x26,6	2.5"x10.5"	57	/	14,40	2.850	50	50,00	800
Jolly	1,2x26,6	0.5"x10.5"	4	/	0,23	/	/	/	/
Färgblock lucido/matt	5x15	2"x6"	80	0,6	10,90	6720	84	50,4	936
Genesi	6,5x26,6	2.5"x10.5"	57	1,00	15,60	2.850	50	50,00	800
Genesi	6,5x13,2	2.5"x5.2"	58	0,50	7,79	5.510	95	47,50	760
Genesi	6,5x40	2.5"x15.8"	38	1,00	15,00	1.900	50	50,00	770
Genesi	13,2x40	5.2"x15.8"	19	1,00	15,60	950	50	50,00	800
Genesi	13,2x13,2	5.2"x5.2"	57	1,00	15,60	2.850	50	50,00	800
Jolly	1,2x26,6	0.5"x10.5"	4	/	0,23	/	/	/	/
Bullnose Lineare	6,5x26,6	2.5"x10.5"	57	/	14,40	2.850	50	50,00	800
Marea	7,5X30	3"x11.8"	24	0,54	7,90	2.304	96	51,84	778,40
Alta-marea	7,5X30	3"x11.8"	20	0,45	8,05	1.920	96	43,20	792,80
Bassa-marea	7,5X30	3"x11.8"	22	0,50	8,00	2.112	96	48,00	788,00
Jolly Marea	1,2x30	0.5"x11.8"	6	/	0,40	/	/	/	/
Minima8.6	17x15	6.7"x5.9"	29	0,57	11,25	2.320	80	45,60	920
Multicolor	17x15	6.7"x5.9"	29	0,57	11,25	2.320	80	45,60	920
Modulo base	5,6x23,2	2.2"x9.1"	40	0,52	8,80	3.800	95	49,40	856
Modulo inciso	5,6x23,2	2.2"x9.1"	36	0,47	8,60	3.420	95	44,65	837
Modulo tondi	5,6x23,2	2.2"x9.1"	4	/	0,88	/	/	/	/
Oltre base	18,6X18,6	7.3"x7.3"	13	0,45	8,30	1404	108	48,6	920
Oltre3	18,6X18,6	7.3"x7.3"	13	0,45	8,30	1404	108	48,6	920
Oltre9	18,6X18,6	7.3"x7.3"	13	0,45	8,30	1404	108	48,6	920
Pigmento10	10x10	4"x4"	50	0,5	9,50	4.500	90	45	875
Pigmento	6x37	2.4"x14.5"	46	1	18,90	2300	50	50	965
Pigmento lustro	6x37	2.4"x14.5"	6	/	2,46	/	/	/	/
Porticciolo Brezza	5x25	2"x10"	40	0,50	7,78	3.600	90	45,00	720
Jolly	1,2x25	0.5"x10"	4	/	0,23	/	/	/	/
Base Riquadri	13,2x26,6	5.2"x10.5"	28	1,00	15,00	1.400	50	50,00	770
Riquadri	13,2x26,6	5.2"x10.5"	28	1,00	15,00	1.400	50	50,00	770
Jolly	1,2x26,6	0.5"x10.5"	4	/	0,23	/	/	/	/
Sfumature	6,5x33	2.5"x13"	52	1,00	14,80	2.600	50	50,00	760
Sfumature effetti	6,5x33	2.5"x13"	52	1,00	15,20	2.600	50	50,00	780
Jolly	1,2x26,6	0.5"x10.5"	4	/	0,23	/	/	/	/
Tinte lucido/matt	5x25	2"x10"	40	0,50	7,10	3.600	90	45,00	660
Superfici20	20x20	8"x8"	24	0,96	20,74	1296	54	51,84	1140
Muretto	20x20	8"x8"	9	0,36	7,25	720	80	28,80	600
Mosaico	20x20	8"x8"	12	0,48	9,60	900	75	36,00	740
Decoro tracce mix	20x20	8"x8"	5	0,20	4,32	/	/	/	/

CARATTERISTICHE TECNICHE

TECHNICAL FEATURES

GRES PORCELLANATO SMALTATO
GLAZED PORCELAIN

	NORMA standard	VALORE RICHIESTO required standards	ALCHIMIA	CONFETTI	FÄRGBLOCK LUCIDO	FÄRGBLOCK MATT	MINIMA8.6	MODULO	OLTRE	PIGMENTO	PIGMENTO10	SUPERFICI20	
DIMENSIONI dimensions	LUNGHEZZA E LARGHEZZA length and width	UNI-EN ISO 10545-2	± 0.6%	CONFORME compliant	CONFORME compliant	CONFORME compliant	CONFORME compliant	CONFORME compliant	CONFORME compliant	CONFORME compliant	CONFORME compliant	CONFORME compliant	
	SPESSORE thickness	UNI-EN ISO 10545-2	± 5%	CONFORME compliant	CONFORME compliant	CONFORME compliant	CONFORME compliant	CONFORME compliant	CONFORME compliant	CONFORME compliant	CONFORME compliant	CONFORME compliant	
	RETTILINEITÀ DEGLI SPIGOLI straightness of sides	UNI-EN ISO 10545-2	± 0.5%	CONFORME compliant	CONFORME compliant	CONFORME compliant	CONFORME compliant	CONFORME compliant	CONFORME compliant	CONFORME compliant	CONFORME compliant	CONFORME compliant	
	ORTOGONALITÀ rectangularity	UNI-EN ISO 10545-2	± 0.5%	CONFORME compliant	CONFORME compliant	CONFORME compliant	CONFORME compliant	CONFORME compliant	CONFORME compliant	CONFORME compliant	CONFORME compliant	CONFORME compliant	
	PLANARITÀ - CURVATURA DEL CENTRO surface flatness – centre curvature	UNI-EN ISO 10545-2	± 0.5%	CONFORME compliant	CONFORME compliant	CONFORME compliant	CONFORME compliant	CONFORME compliant	CONFORME compliant	CONFORME compliant	CONFORME compliant	CONFORME compliant	
	PLANARITÀ - CURVATURA DELLO SPIGOLO surface flatness – edge curvature	UNI-EN ISO 10545-2	± 0.5%	CONFORME compliant	CONFORME compliant	CONFORME compliant	CONFORME compliant	CONFORME compliant	CONFORME compliant	CONFORME compliant	CONFORME compliant	CONFORME compliant	
RESISTENZA ALLA FLESSIONE bending strenght	PLANARITÀ - SVERGOLAMENTO surface flatness – warpage	UNI-EN ISO 10545-2	± 0.5%	CONFORME compliant	CONFORME compliant	CONFORME compliant	CONFORME compliant	CONFORME compliant	CONFORME compliant	CONFORME compliant	CONFORME compliant	CONFORME compliant	
	CARICO DI ROTTURA breaking strenght	UNI-EN ISO 10545-4	> 1300 N (≥ 7,5 MM) > 700 N (< 7,5 MM)	CONFORME compliant	CONFORME compliant	CONFORME compliant	CONFORME compliant	CONFORME compliant	CONFORME compliant	CONFORME compliant	CONFORME compliant	CONFORME compliant	
	MODULO DI ROTTURA modulus of rupture	UNI-EN ISO 10545-4	> 35 N/MM² (≥ 7,5 MM)	CONFORME compliant	CONFORME compliant	CONFORME compliant	CONFORME compliant	CONFORME compliant	CONFORME compliant	CONFORME compliant	CONFORME compliant	CONFORME compliant	
	RESISTENZA ALL'ABRASIONE DELLE PIASTRELLE SMALTATE resistance to abrasion of glazed tiles	UNI-EN ISO 10545-7	-	PEI 3: COLORI CHIARI pei 3: light colors	PEI 4	PEI 3: COLORI CHIARI pei 3: light colors PEI 2: COLORI SCURI pei 2: dark colors	PEI 3: COLORI CHIARI pei 3: light colors PEI 2: COLORI SCURI pei 2: dark colors	PEI 4: BIANCO / white PEI 3: COLORI CHIARI E MULTICOLOR pei 3: light colors and multicolor PEI 2: COLORI SCURI pei 2: dark colors	PEI 4: COLORI CHIARI pei 4: light colors PEI 3: COLORI SCURI pei 3: dark colors	PEI 3: TUTTI I COLORI pei 3: all colors PEI 2: NERO pei 2: black	PEI 3: COLORI CHIARI pei 3: light colors PEI 2: COLORI SCURI pei 2: dark colors	PEI 3: COLORI CHIARI pei 3: light colors PEI 2: COLORI SCURI pei 2: dark colors	PEI 4: GRIGIO PEI 4: PERLA PEI 3: ANTRACITE
	ASSORBIMENTO D'ACQUA water absorption	UNI-EN ISO 10545-3	≤ 0,5 %	CONFORME compliant	CONFORME compliant	CONFORME compliant	CONFORME compliant	CONFORME compliant	CONFORME compliant	CONFORME compliant	CONFORME compliant	CONFORME compliant	
	RESISTENZA DEI COLORI ALLA LUCE colour resistance to light	DIN 51094	-	RESISTENTE resistant	RESISTENTE resistant	RESISTENTE resistant	RESISTENTE resistant	RESISTENTE resistant	RESISTENTE resistant	RESISTENTE resistant	RESISTENTE resistant	RESISTENTE resistant	
	COEFFICIENTE DI DILATAZIONE TERMICA LINEARE (100° C) linear thermal expansion coefficient (100° C)	UNI-EN ISO 10545-8	-	METODO DISPONIBILE test method available	METODO DISPONIBILE test method available	METODO DISPONIBILE test method available	METODO DISPONIBILE test method available	METODO DISPONIBILE test method available	METODO DISPONIBILE test method available	METODO DISPONIBILE test method available	METODO DISPONIBILE test method available	METODO DISPONIBILE test method available	
	RESISTENZA AGLI SBALZI TERMICI thermal shock resistance	UNI-EN ISO 10545-9	-	RESISTENTE resistant	RESISTENTE resistant	RESISTENTE resistant	RESISTENTE resistant	RESISTENTE resistant	RESISTENTE resistant	RESISTENTE resistant	RESISTENTE resistant	RESISTENTE resistant	
	RESISTENZA AL GELO frost resistance	UNI-EN ISO 10545-12	-	RESISTENTE resistant	RESISTENTE resistant	RESISTENTE resistant	RESISTENTE resistant	RESISTENTE resistant	RESISTENTE resistant	RESISTENTE resistant	RESISTENTE resistant	RESISTENTE resistant	
	RESISTENZA AL CAVILLO crazing resistance	UNI-EN ISO 10545-11	-	RESISTENTE resistant	RESISTENTE resistant	RESISTENTE resistant	RESISTENTE resistant	RESISTENTE resistant	RESISTENTE resistant	RESISTENTE resistant	RESISTENTE resistant	RESISTENTE resistant	
	RESISTENZA ALLE MACCHIE resistance to stains	UNI-EN ISO 10545-14	CLASSE 3 MIN.	CLASSE 5 Class 5	CLASSE 5 Class 5	CLASSE 5 Class 5	CLASSE 5 Class 5	CLASSE 5 Class 5	CLASSE 5 Class 5	CLASSE 5 Class 5	CLASSE 5 Class 5	CLASSE 3 MIN Class 3	
	RESISTENZA CHIMICA chemical resistance	UNI-EN ISO 10545-13	GB MIN.	GARANTITA guaranteed (GA GLA GHA)	GARANTITA guaranteed (GA GLA GHA)	GARANTITA guaranteed (GA GLA GHA)	GARANTITA guaranteed (GA GLA GHA)	GARANTITA guaranteed (GA GLA GHA)	GARANTITA guaranteed (GA GLA GHA)	GARANTITA guaranteed (GA GLA GHA)	GARANTITA guaranteed (GA GLA GHA)	GB MIN.	
	PIOMBO E CADMIO RILASCIATI lead and cadmium given off	UNI-EN ISO 10545-15	-	METODO DISPONIBILE test method available	METODO DISPONIBILE test method available	METODO DISPONIBILE test method available	METODO DISPONIBILE test method available	METODO DISPONIBILE test method available	METODO DISPONIBILE test method available	METODO DISPONIBILE test method available	METODO DISPONIBILE test method available	METODO DISPONIBILE test method available	
	REAZIONE AL FUOCO reaction to fire	EN 13501-1	-	A1 _{FL} -A1	A1 _{FL} -A1	A1 _{FL} -A1	A1 _{FL} -A1	A1 _{FL} -A1	A1 _{FL} -A1	A1 _{FL} -A1	A1 _{FL} -A1	A1 _{FL} -A1	
	ANGOLO CRITICO DI SLITTAMENTO slip resistance (ramp test)	DIN 51130	-	R9	R10	-	R9	R9	R9	R9	R9	ROCCIA + CEMENTO: R10 SLATE + RIGA: R9	
	RESISTENZA ALLO SLITTAMENTO slip resistance (pendulum test)	UNI-EN ISO 16165 C	-	44 WET	38 PTV	-	40WET	37WET	37WET	37WET	37WET	ROCCIA + CEMENTO: 50 WET SLATE + RIGA: 36 WET	
	RESISTENZA ALLO SLITTAMENTO slip resistance (pendulum test)	AS/NZS 4586	-	P3	P3	-	P3	P3	P2	P3	P3	P3	
	COEFFICIENTE DINAMICO DI ATTRITO SUL BAGNATO (DCOF) wet dynamic coefficient of friction (DCOF)	ANSI A137.1-BOT 3000	≥ 0.42	0.68	0.72	-	CONFORME compliant	CONFORME compliant	CONFORME compliant	CONFORME compliant	CONFORME compliant	CONFORME compliant	
	VARIAZIONE DI TONO shade variations	-	-	BIANCO - GRIGIO - NERO: V1 ELISIR: V1 ARS MIX: V4	V4	V1	V1	MULTICOLOR: V4 TINTE UNITA: V1 plain color: V1	V1	V1	V3	V3	CEMENTO: V2 ROCCIA - RIGA: V3 SLATE: V4

GRES PORCELLANATO SMALTATO GLAZED PORCELAIN
Piastrine di ceramica pressate a secco con assorbimento d'acqua Eb ≤ 0,5 %. Caratteristiche di qualità secondo i test di controllo previsti dalla norma EN14411:2013 appendice G gruppo B1a GL. Dry-pressed ceramic tiles with water absorption Eb ≤ 0,5 %. Quality specification, according to control test of EN14411: 2013 appendix L group B1a GL

CARATTERISTICHE TECNICHE

TECHNICAL FEATURES

RIVESTIMENTO IN PASTA BIANCA
WHITE BODY WALL TILES

	NORMA standard	VALORE RICHIESTO required standards	3LATI	CROMIA26	GENESI	MAREA	PORTICCIOLO	RIQUADRI	SFUMATURE	TINTE
DIMENSIONI dimensions	LUNGHEZZA E LARGHEZZA length and width	UNI-EN ISO 10545-2	± 0.5%	CONFORME compliant	CONFORME compliant	CONFORME compliant	CONFORME compliant	CONFORME compliant	CONFORME compliant	CONFORME compliant
	SPESSORE thickness	UNI-EN ISO 10545-2	± 10%	CONFORME compliant	CONFORME compliant	CONFORME compliant	CONFORME compliant	CONFORME compliant	CONFORME compliant	CONFORME compliant
	RETTILINEITÀ DEGLI SPIGOLI straightness of sides	UNI-EN ISO 10545-2	± 0.3%	CONFORME compliant	CONFORME compliant	CONFORME compliant	CONFORME compliant	CONFORME compliant	CONFORME compliant	CONFORME compliant
	ORTOGONALITÀ rectangularity	UNI-EN ISO 10545-2	± 0.5%	CONFORME compliant	CONFORME compliant	CONFORME compliant	CONFORME compliant	CONFORME compliant	CONFORME compliant	CONFORME compliant
	PLANARITÀ - CURVATURA DEL CENTRO surface flatness – centre curvature	UNI-EN ISO 10545-2	± 0.5% - 0.3%	CONFORME compliant	CONFORME compliant	CONFORME compliant	CONFORME compliant	CONFORME compliant	CONFORME compliant	CONFORME compliant
RESISTENZA ALLA FLESSIONE bending strenght	PLANARITÀ - CURVATURA DELLO SPIGOLO surface flatness – edge curvature	UNI-EN ISO 10545-2	± 0.5% - 0.3%	CONFORME compliant	CONFORME compliant	CONFORME compliant	CONFORME compliant	CONFORME compliant	CONFORME compliant	CONFORME compliant
	PLANARITÀ - SVERGOLAMENTO surface flatness – warpage	UNI-EN ISO 10545-2	± 0.5%	CONFORME compliant	CONFORME compliant	CONFORME compliant	CONFORME compliant	CONFORME compliant	CONFORME compliant	CONFORME compliant
	CARICO DI ROTTURA breaking of rupture	UNI-EN ISO 10545-4	> 600 N (≥ 7,5 MM) > 200 N (< 7,5 MM)	CONFORME compliant	CONFORME compliant	CONFORME compliant	CONFORME compliant	CONFORME compliant	CONFORME compliant	CONFORME compliant
	MODULO DI ROTTURA modulus of rupture	UNI-EN ISO 10545-4	> 12 N/MM² (≥ 7,5 MM) > 15 N/MM² (< 7,5 MM)	CONFORME compliant	CONFORME compliant	CONFORME compliant	CONFORME compliant	CONFORME compliant	CONFORME compliant	CONFORME compliant
ASSORBIMENTO D'ACQUA water absorption	UNI-EN ISO 10545-3	> 10 %	CONFORME compliant	CONFORME compliant	CONFORME compliant	CONFORME compliant	CONFORME compliant	CONFORME compliant	CONFORME compliant	CONFORME compliant
RESISTENZA DEI COLORI ALLA LUCE colour resistance to light	DIN 51094	-	RESISTENTE resistant	RESISTENTE resistant	RESISTENTE resistant	CONFORME compliant	RESISTENTE resistant	RESISTENTE resistant	RESISTENTE resistant	RESISTENTE resistant
COEFFICIENTE DI DILATAZIONE TERMICA LINEARE (100° C) linear thermal expansion coefficient (100° C)	UNI-EN ISO 10545-8	-	METODO DISPONIBILE test method available	METODO DISPONIBILE test method available	METODO DISPONIBILE test method available	METODO DISPONIBILE test method available	METODO DISPONIBILE test method available	METODO DISPONIBILE test method available	METODO DISPONIBILE test method available	METODO DISPONIBILE test method available
RESISTENZA AGLI SBALZI TERMICI thermal shock resistance	UNI-EN ISO 10545-9	-	RESISTENTE* resistant*	RESISTENTE resistant	RESISTENTE resistant	RESISTENTE* resistant	RESISTENTE resistant	RESISTENTE resistant	RESISTENTE resistant	RESISTENTE* resistant
RESISTENZA AL CAVILLO crazing resistance	UNI-EN ISO 10545-11	-	RESISTENTE* resistant*	RESISTENTE resistant	RESISTENTE resistant	RESISTENTE* resistant	RESISTENTE resistant	RESISTENTE resistant	RESISTENTE resistant	RESISTENTE* resistant
RESISTENZA ALLE MACCHIE resistance to stains	UNI-EN ISO 10545-14	CLASSE 3 MIN.	CLASSE 5* Class 5*	CLASSE 5* Class 5	CLASSE 5 Class 5	CLASSE 5* Class 5	CLASSE 5 Class 5	CLASSE 5 Class 5	CLASSE 5 Class 5	CLASSE 5* Class 5
RESISTENZA CHIMICA chemical resistance	UNI-EN ISO 10545-13	GB MIN.	GARANTITA* guaranteed* (GA GLA GHA)	GARANTITA* guaranteed (GA GLA GHA)	GARANTITA guaranteed (GA GLA GHA)	GARANTITA* guaranteed (GA GLA GHA)	GARANTITA guaranteed (GA GLA GHA)	GARANTITA guaranteed (GA GLA GHA)	GARANTITA guaranteed (GA GLA GHA)	GARANTITA* guaranteed (GA GLA GHA)
PIOMBO E CADMIO RILASCIATI lead and cadmium given off	UNI-EN ISO 10545-15	-	METODO DISPONIBILE test method available	METODO DISPONIBILE test method available	METODO DISPONIBILE test method available	METODO DISPONIBILE test method available	METODO DISPONIBILE test method available	METODO DISPONIBILE test method available	METODO DISPONIBILE test method available	METODO DISPONIBILE test method available
REAZIONE AL FUOCO reaction to fire	EN 13501-1	-	A1	A1 _{fl} -A1	A1	A1	A1	A1	A1	A1
VARIAZIONE DI TONO shade variations	-	-	BIANCO/white: V1 ALTRI COLORI:V3 other colors: v3	V1	V1	V1	BREZZA: V4	BIANCO/white: V1 ALTRI COLORI:V3 other colors: v3	V3	BIANCO, NERO, ACCIAIO: V1 bianco, nero, acciaio: v1 ALTRI COLORI: V3 other colors: v3

RIVESTIMENTO IN MONOPOROSA PASTA BIANCA GLAZED WHITE-BODIED POROUS SINGLE-FIRED WALL TILES.
Piastrille di ceramica pressate a secco con assorbimento d'acqua Eb > 10 %. Caratteristiche di qualità secondo i test di controllo previsti dalla norma EN14411:2013 appendice L gruppo BIII GL.
Dry-pressed ceramic tiles with water absorption Eb > 10 %. Quality specification, according to control test of EN14411:2013 appendix L group BIII GL
*AD ECCEZIONE DEI COLORI METALLIZZATI (oro, bronzo, acciaio) EXCLUDING METALLIC COLORS (oro, bronzo, acciaio)

CONDIZIONI GENERALI DI VENDITA

GENERAL TERMS AND CONDITIONS OF SALE
CONDITIONS GÉNÉRALES DE VENTE

ISTRUZIONI DI POSA E MANTENIMENTO

INSTALLATION AND MAINTENANCE GUIDE
INSTRUCTIONS DE POSE ET D'ENTRETIEN

CONDIZIONI GENERALI DI VENDITA

1. Normativa contrattuale

Le presenti condizioni generali, salve eventuali modifiche o deroghe concordate per iscritto, disciplinano tutti i contratti di vendita, relativi ai Prodotti commercializzati da QUINTESSENZA CERAMICHE ("Venditore"), conclusi fra il Venditore e l'Acquirente. Le variazioni delle condizioni generali di vendita, le transazioni e gli abbouini, anche se effettuati su iniziativa di nostri agenti, procuratori o altri intermediari, saranno impegnative per il Venditore solo dopo conferma scritta e comunque limitatamente al singolo contratto cui si riferiscono.

2. Accettazione e conferma dell'ordine

L'ordine del cliente vale come proposta d'acquisto; esso è irrevocabile per il Cliente e non è vincolante per il Venditore che si riserva il diritto di accettarlo. Il contratto di vendita s'intenderà concluso soltanto dopo la conferma d'ordine scritta da parte del Venditore; nulla ricevendo entro 48h si riterrà la conferma d'ordine integralmente accettata. Quanto contemplato nella conferma d'ordine del Venditore annulla eventuali accordi o trattative che non siano riportati nella conferma stessa. Quanto sopra vale anche per eventuali cessioni gratuite per sala mostra. Prima di evadere gli ordini, il Venditore si riserva la facoltà di richiedere informazioni commerciali sul nome dell'Acquirente che, a suo insindacabile giudizio, sconsigliano l'esecuzione o la prosecuzione del contratto; l'esercizio di tale facoltà non attribuisce all'Acquirente alcun diritto al risarcimento di danni od altro.

3. Prezzi

Salvo quanto diversamente concordato dal Venditore per iscritto, i prezzi validi sono quelli del listino in vigore al momento della spedizione. I prezzi si intendono per consegna "Franco Fabbrica" e non comprendono altri oneri come: I.V.A., bolli, spese di spedizioni e imballo, dazi doganali o tasse di qualsiasi natura che saranno sempre a carico dell'Acquirente. Il Venditore si riserva la facoltà di modificare i prezzi del presente listino con un preavviso di 30 (trenta) giorni.

note:

Prezzi in Euro - I.V.A e trasporto esclusi

Costo Pallet € 10,00

Tutti i prodotti vengono venduti solo a colli interi

Spese di spedizione per consegna presso deposito nell'area di Sassuolo e Fiorano: €25,00 a paletta.

4. Termini di consegna e recesso

I termini di consegna eventualmente specificati dal Venditore non sono da considerarsi impegnativi, ma puramente indicativi. Il Venditore si riserva il diritto di cancellare, sospendere o ritardare, in tutto o in parte, qualsiasi ordine per ragioni di forza maggiore e per qualsiasi altro evento al di fuori del controllo del Venditore (ivi compreso stato di allarme, mobilitazione, blocco guerra o calamità naturali anche in stati fornitori di materie prime, crisi energetica, forzata restrizione della produzione, scioperi, occupazioni di stabilimento, serrata, incendi, crolli, ecc...) tali che alterino in modo sostanziale lo stato dei mercati, il valore della moneta e le condizioni dell'industria delle ceramiche. Il Venditore si riserva anche il diritto di cessare la produzione di particolari prodotti per esigenze o problemi di produzione o di mercato. L'Acquirente rinuncia a qualsiasi ed ogni rivendicazione per cancellazione di ordini o ritardi nella consegna dei Prodotti, ivi comprese, senza limitazioni, pretese per danni diretti, indiretti, accidentali, consequenziali o altri danni o compensazioni

5. Trasporto

La merce viaggia a rischio e pericolo dell'Acquirente in quanto reso "franco fabbrica". Tale condizione è valida anche nel caso di utilizzo di Vettore e/o Spedizioniere da noi contattato e pagato anticipatamente nell'interesse dell'Acquirente stesso e nel caso di vendita "franco destino". La responsabilità del Venditore cessa con la consegna al vettore. I reclami per eventuali ammanchi, rotture alterazione degli imballaggi o qualunque altra ragione o fatto imputabile al trasporto dovranno essere rivolti esclusivamente al Vettore.

6. Pagamenti

Le fatture non contestate entro 8 (otto) gg. dal ricevimento si intendono accettate. Il corrispettivo di ogni fattura dovrà essere pagato con le modalità e nei termini pattuiti in essa indicati. Il luogo del pagamento resta fissato presso la sede amministrativa del Venditore o presso istituto bancario da esso indicato. L'accettazione da parte del Venditore di assegni, sarà salvo buon fine e non costituirà pagamento fino a quando il Venditore non avrà incassato l'intero importo. Pagamenti effettuati ad agenti del Venditore non saranno liberatori per l'acquirente se non previa specifica autorizzazione scritta del Venditore. Qualsiasi ritardo nel pagamento o insoluto su Ri.Ba, darà al Venditore il diritto di risolvere i contratti in corso o di sospendere le consegne della merce o di pretendere il pagamento anticipato, anche con riferimento ad altri contratti, nonché il diritto al recupero di tutte le spese e degli interessi di mora al tasso corrente e al risarcimento degli eventuali danni subiti, senza alcun diritto per l'Acquirente ad avanzare pretese, indennizzi od altro.

Nel caso in cui il Venditore intraprenda procedure per incassare qualsiasi importo dovuto dall'Acquirente, oppure per fare valere qualsiasi diritto derivante dal contratto, incluso il riservato dominio, l'Acquirente dovrà rimborsare al Venditore tutte le spese, competenze ed onorari del giudizio.

7. Riservato Dominio

Fino a quando il Venditore non avrà ottenuto dall'Acquirente il pagamento completo dei Prodotti, il Venditore mantiene il diritto di proprietà sui Prodotti stessi, secondo quanto previsto dall'articolo 1523 e seguenti del Codice Civile Italiano. Il mancato pagamento anche di una sola rata produrrà lo scioglimento del contratto con la facoltà di esigere l'immediato pagamento di tutte le rate anche non scadute ovvero l'immediata restituzione della merce. In tal caso le somme versate resteranno acquisite al venditore a titolo di indennità.

8. Garanzia

I prodotti di QUINTESSENZA CERAMICHE sono garantiti conformi alle norme UNI-EN in vigore. L'Acquirente riconosce che le variazioni di calibro, colore, tonalità o altre caratteristiche visive della merce, anche tra piastrelle di fondo e decorate, sono caratteristiche dei Prodotti e sono ad essi intrinseche ed inevitabili, e che i campioni del Venditore sono solo approssimativi dei Prodotti. In nessun caso il Venditore potrà dare, o si considererà avere dato, alcuna garanzia, espressa o implicita, in relazione a dichiarazioni, descrizioni o illustrazioni contenute in qualsiasi opuscolo o documentazione. Inoltre qualsiasi garanzia scritta fatta dal Venditore all'Acquirente non vale per Prodotti in seconda o terza scelta o partite occasionali, ma è limitata esclusivamente ai Prodotti di prima scelta e con una tolleranza del 5% circa. Al ricevimento dei Prodotti l'Acquirente dovrà sottoporli ad un accurato controllo, aprendo le scatole. L'Acquirente assume piena e completa responsabilità per verificare se i Prodotti sono conformi a quelli ordinati o sono adatti all'uso che l'Acquirente ne vuole fare, indipendentemente da qualsiasi suggerimento o istruzione dati dal Venditore relativamente ai Prodotti o al loro uso.

9. Reclami

I reclami su eventuali ammanchi o rotture dovranno essere fatti esclusivamente al Vettore (al momento dello scarico del materiale con annotazione sul documento di trasporto), dandone immediata comunicazione scritta al Venditore. Qualsiasi altro reclamo relativo alla natura e/o caratteristica del materiale dovrà essere tempestivamente inoltrato al Venditore per iscritto e comunque entro 8 giorni dal ricevimento della merce. Trascorso tale termine si intende che la merce è stata vista ed accettata nello stato in cui si trova, pena la decadenza della garanzia. Eventuali difetti occulti della merce dovranno essere denunciati, con le stesse modalità di cui sopra entro 8 giorni dalla scoperta e comunque entro 1 anno dalla consegna, pena la decadenza dalla garanzia. Il cliente decadrà inoltre dalla garanzia se, dopo la tempestiva denuncia non manterrà il materiale a disposizione del Venditore o se lo utilizzerà. Non si accettano reclami relativi a materiale già posto in opera. Ove siano accertati difetti il Venditore potrà a sua scelta, sostituire i Prodotti contestati oppure annullare o risolvere il contratto, in tutto o in parte, senza l'obbligo di sostituzione dei Prodotti. L'Acquirente rinuncia a qualsiasi altra rivendicazione, ivi compresa, senza limitazioni, rivendicazioni per danni diretti, indiretti, accidentali, consequenziali o altri danni o compensazioni e al diritto di annullare o risolvere il contratto.

10. Trattamento dati personali

Privacy: la versione integrale è visionabile presso la sede sociale di Quintessenza Ceramiche. Informativa ai sintesi dell'Art.13 D. Lgs. 196/2003. I dati sono trattati a norma di legge di cui all'Art. 7-8-9 D.Lgs 196/2003.

11. Diritto applicabile e foro competente

I contratti sono regolati ed interpretati in conformità al diritto italiano. Per qualsiasi controversia o contestazione emersa tra le parti, il solo e unico Foro competente sarà quello di Modena (Italia).

GENERAL TERMS AND CONDITIONS OF SALE

EN

1. Contractual conditions

Except in the presence of amendments or derogations agreed in writing, these general terms of sale shall govern all sales contracts concerning the products distributed by QUINTESSENZA CERAMICHE (“Seller”) entered into between the Seller and the Purchaser . Any amendments to the general terms of sale, transactions and allowances, even if proposed on the initiative of our agents, brokers or other intermediaries, shall be binding on the Seller exclusively in the presence of written confirmation and anyway only with regard to the single contract to which they refer.

2. Order acceptance and confirmation

The Client’s order is a purchase proposal; orders are irrevocable for the Client and non-binding on the Seller, which reserves the right to accept or decline them. The contract of sale shall be deemed to have been entered into only after a written order confirmation is issued by the Seller; if no objection is received within the following 48 hour period the order shall be deemed to have been confirmed and accepted in full. The contents of the Seller’s order confirmation shall prevail with respect to any agreements or negotiations that are not referred to in said order confirmation. The above also applies to any deliveries of material free of charge for exhibition purposes. Before filling orders, the Seller reserves the right to request business information concerning the Purchaser such that may, at the sole discretion of the Seller, advise against the execution or continuation of the contract; the exercise of said power shall not grant the Purchaser any whatsoever right to claim compensation for damages or any other rights.

3. Prices

Unless otherwise specifically agreed by Seller in writing, the valid prices are those indicated on the price-list that is in force at the time of shipment. All prices are for delivery “Ex-Factory” and do not include other charges such as: VAT, stamp duty, shipping and Packing costs, customs duties or any type of tax, which shall always be at the entire expense of the Purchaser. The Seller reserves the right to amend the prices on this price-list on giving advance notice of 30 (thirty) days.

notes:

Prices in euro – VAT and transport non included

Pallet cost € 10.00

All products are sold only by full boxes

Shipping costs to warehouse in the Sassuolo and Fiorano area: €25.00 per pallet

4. Terms of delivery and cancellation

Any delivery terms specified by Seller are never binding but only guideline. The Seller reserves the right to cancel, suspend or delay, entirely or in part, any orders due to events of force majeure or other events beyond the Seller’s control (including states of emergency, mobilization, war, or natural disasters, also in the countries of raw material suppliers, energy crises, forced output restrictions, strikes, factory lock-outs, fires, collapses, etc.) such that substantially affect the condition of the market, the value of the currency, and the conditions of the ceramic industry. The Seller also reserves the right to discontinue particular merchandise for reasons of production problems or market requirements. The Purchaser waives any and all claims and rights relating to any cancellation or delay in delivery of the goods including, without limitation, any and all claims for direct, indirect, incidental, consequential or other damages or compensation.

5. Transport

The goods travel at the risk and peril of the Purchaser as sold “Ex-Factory”. This condition also applies in case of the use of a carrier and/or forwarding agent contacted and paid in advance by our comany on the Purchaser’s behalf and/or in case of sales made at “Carriage paid” conditions. The liability of the Seller ends on handing over the products to the carrier. Therefore, claims for any shortages, breakages, damaged Packing or for any reason or fact attributable to the transport of the goods must be addressed exclusively to the Carrier.

6. Payments

Invoices that are not disputed within 8 (eight) days of receipt are considered to have been accepted. The sum of each invoice must be paid using the methods and within the terms stipulated and indicated on the invoice. The place of payment is the administrative office of the Seller or the bank indicated by the Seller. The Seller’s acceptance of cheques shall be construed as subject to collection and shall not constitute effective payment for the goods until the Seller has collected the full amount. Payments made to the Seller’s agents shall not release the Purchaser from its obligation to remit unless they are preceded by specific written authorization given by the Seller. Any delay in payment or outstanding debt on Bank Orders shall entitle the Seller to terminate the current contracts, suspend delivery of the goods or demand payment in advance, even with reference to other contracts, and to recover all expenses and late payment interest at the current rate and also seek compensation for any damages incurred, without giving rise to any right on the part of the Purchaser to make demands, claim compensation or make any other claims.

If the Seller initiates legal proceedings to collect any amounts owed by the Purchaser or to enforce any right deriving from the contract, including title retention, the Purchaser shall reimburse to the Seller all the associated legal costs, expenses, and fees.

7. Title retention

Until the Seller has collected full payment for the products from the Purchaser, the Seller retains the title of ownership of the Products, in accordance with article 1523 et seq of the Italian Civil Code. Failure to pay even a single instalment shall lead to termination of the agreement and the right to demand immediate payment of all instalments, even those not yet due, or immediate return of the goods. In this case the amounts already paid shall be withheld by the Seller by way of indemnity.

8. Warranty

Compliance of QUINTESSENZA CERAMICHE products with the applicable UNI-EN standards in force is guaranteed. The Purchaser acknowledges that variations in size, colour, tone or other visual characteristics of the products also between plain tiles and decorative tiles, are characteristics of the Products and are intrinsic to them and unavoidable, and also acknowledges that the Seller’s samples are only provided as approximations of the Products. Under no circumstances can the Seller make, or shall be deemed to have made, any warranty, express or implied, in relation to any statements, descriptions or illustrations in any brochure or other literature. Moreover, any written warranty made by Seller to the Purchaser does not apply to second or third grade sorted Products or occasional lots but refers exclusively to first grade Products with a tolerance of approximately 5%. Upon receipt of the Products, the Purchaser shall open the boxes to check them carefully. The Purchaser assumes full and complete responsibility for ascertaining whether the Products correspond to the Products ordered and are suitable for the intended use, regardless of any suggestion or direction given by Seller with respect to the Products or the use thereof.

9. Claims

Claims concerning shortages or breakages must be solely addressed to the Carrier (when the material is unloaded, with a suitable note made on the transport document) and immediately informing the Seller of the matter in writing. Any other claim concerning the nature and/or characteristics of the material must be forwarded to the Seller in writing promptly and anyway within 8 days from receipt of the goods. One said term has elapsed the goods shall be considered seen and accepted in the state in which they were received on pain of forfeiture of the warranty cover. Any hidden defects of the goods must be reported as stated above, within 8 (eight) days from the time of discovery although within 1 year from the date of delivery on pain of forfeiture of the warranty cover. The Purchaser shall also forfeit the warranty if, after making a timely claim, it fails to keep the affected material available for the Seller, or if the material is utilized in the interim. Claims concerning material that has already been installed shall not be accepted. In the event of ascertained defects, the Seller may, at its discretion, either replace the affected material or cancel or terminate the Contract, in whole or in part, without any obligation to replace the Products. The Buyer waives any and all other claims, including, without limitation, any and all claims for or rights to direct, indirect, incidental, consequential, punitive or other compensation or damages, and any and all rights to terminate or cancel the contract.

10. Processing of personal data

Data protection: the unabridged privacy practices are available at headquarters of Quintessenza Ceramiche. Abridged privacy practices in compliance with Art.13 of Italian decree D. Lgs. 196/2003. Data are processed in accordance with the law pursuant to Articles 7-8-9 of Italian decree D.Lgs 196/2003.

11. Applicable law and jurisdiction

The contracts shall be governed and interpreted in accordance with Italian law. For any disputes or claims that arise between the parties, the court of Modena (Italy) shall be the exclusive court of jurisdiction.

CONDITIONS GÉNÉRALES DE VENTE

FR

1. Règles contractuelles

Les présentes conditions générales, sous réserve d’éventuelles modifications ou dérogations convenues par écrit, régissent tous les contrats de vente relatifs aux Produits commercialisés par QUIN-TESSENZA CERAMICHE (« Vendeur »), conclus entre le Vendeur et l’Acheteur. Les modifications des conditions générales de vente, les transactions et les remises, même si celles-ci sont proposées à l’initiative de nos agents, apporteurs d’affaires ou autres intermédiaires, ne seront contraignantes pour le Vendeur qu’après confirmation écrite et, dans tous les cas, ne se limiteront qu’au seul contrat auquel elles se réfèrent.

2. Acceptation et confirmation de la commande

La commande du client équivaut à une proposition d’achat ; celle-ci est irrévocable pour le Client et non contraignante pour le Vendeur, qui se réserve le droit de l’accepter. Le contrat de vente n’est réputé conclu qu’après confirmation écrite de la commande par le Vendeur ; toute absence de réponse dans les 48 heures sera considérée comme une acceptation totale de la confirmation de la commande. Ce qui est indiqué dans la confirmation de commande du Vendeur annule les éventuels accords ou négociations qui ne sont pas indiqués dans la confirmation de commande. Ce qui précède s’applique également aux éventuelles cessions gratuites pour showrooms. Avant de traiter les commandes, le Vendeur se réserve le droit de demander des informations commerciales sur le nom de l’Acheteur pouvant dissuader, à sa seule discrétion, d’exécuter ou de poursuivre le contrat; l’exercice de ce droit ne donne à l’Acheteur aucun droit à des dommages-intérêts ou autre.

3. Prix

Sauf si différemment convenu par écrit par le Vendeur, les prix valables sont ceux indiqués sur la liste en vigueur au moment de l’expédition. Les prix de la livraison sont considérés « Départ Usine » et ne comprennent pas d’autres coûts tels que : TVA, timbres, frais d’expédition et d’emballage, droits de douane ou taxes de toute nature, qui seront toujours à charge de l’Acheteur. Le Vendeur se réserve le droit de modifier les prix de la présente liste avec un préavis de 30 (trente) jours.

Notes:

Prix en Euro - TVA et transport exclus

Coût Palette 10,00 €

Tous les produits sont vendus uniquement par colis entier

Frais d’expédition pour la livraison au dépôt dans la zone de Sassuolo et Fiorano : 25,00 € par palette.

4. Délais de livraison et résiliation

Les délais de livraison éventuellement indiqués par le Vendeur ne sont pas contraignants, mais purement indicatifs. Le Vendeur se réserve le droit d’annuler, de suspendre ou de retarder, totalement ou en partie, toute commande pour des raisons de force majeure ou pour tout autre événement indépendant de la volonté du Vendeur (incluant l’état d’alerte, la mobilisation, la guerre, le blocus ou les catastrophes naturelles, y compris dans les pays fournisseurs de matières premières, la crise énergétique, la restriction forcée de la production, les grèves, les occupations d’usine, les lock-out, les incendies, les effondrements, etc.) altérant de manière substantielle l’état des marchés, la valeur de la monnaie et les conditions de l’industrie de la céramique. Le Vendeur se réserve également le droit d’arrêter la production de certains produits en raison d’exigences ou de problèmes de production ou de marché. L’Acheteur renonce à toute revendication en cas d’annulation de commande ou de retard de livraison des Produits, y compris, sans aucune limitation, les demandes pour dommages directs, indirects, accidentels, consécutifs ou autres dommages ou compensations.

5. Transport

La marchandise voyage aux risques et périls de l’Acheteur car elle est expédiée « départ usine ». Cette condition s’applique également en cas d’utilisation d’un Transporteur et/ou d’un Transitaire contacté par nos soins et payé à l’avance dans l’intérêt de l’Acheteur et en cas de vente « franco de port ». La responsabilité du Vendeur prend fin au moment de la remise au transporteur. Les réclamations concernant les éventuelles quantités manquantes, cassures, altérations des emballages ou toute autre raison ou fait imputable au transport doivent être exclusivement adressées au Transporteur.

6. Paiements

Les factures non contestées dans les 8 (huit) jours suivant leur réception sont considérées comme acceptées. Le montant de chaque facture doit être payé selon les modalités et dans les délais indiqués dans celles-ci. Le lieu de paiement est le siège administratif du Vendeur ou une banque indiquée par ce dernier. L’acceptation de chèques par le Vendeur est subordonnée à leur encaissement et ne constitue pas un paiement tant que le Vendeur n’a pas encaissé le montant total. Les paiements effectués à des agents du Vendeur ne seront pas libératoires pour l’acheteur, sauf autorisation écrite expresse du Vendeur. Tout retard de paiement ou RI.BA impayé relevé donnera au Vendeur le droit de résilier les contrats en cours ou de suspendre les livraisons de marchandises ou d’exiger un paiement anticipé, même en ce qui concerne d’autres contrats, ainsi que le droit de recouvrer tous les frais et intérêts de retard au taux en vigueur et de réclamer une indemnisation pour les dommages subis, sans que l’Acheteur n’ait le droit de présenter de réclamations, de demander des indemnités ou autres.

Si le Vendeur engage une procédure pour recouvrer tout montant dû par l’Acheteur ou pour faire valoir un quelconque droit dérivant du contrat, y compris la réserve de propriété, l’Acheteur devra rembourser au Vendeur tous les frais, honoraires et dépenses liés à la procédure

7.Réserve de propriété

Jusqu’au paiement intégral des Produits par l’Acheteur, le Vendeur conserve la propriété des Produits, conformément aux articles 1523 et suivants du Code civil italien. Le non-paiement même d’un seul versement entraîne la résiliation du contrat avec le droit d’exiger le paiement immédiat de tous les versements, y compris ceux qui ne sont pas en retard, ou la restitution immédiate de la marchandise. Dans ce cas, les sommes versées seront conservées par le vendeur à titre d’indemnité. Jusqu’au paiement intégral des Produits par l’Acheteur, le Vendeur conserve la propriété des Produits, conformément aux articles 1523 et suivants du Code civil italien. Le non-paiement même d’un seul versement entraîne la résiliation du contrat avec le droit d’exiger le paiement immédiat de tous les versements, y compris ceux qui ne sont pas en retard, ou la restitution immédiate de la marchandise. Dans ce cas, les sommes versées seront conservées par le vendeur à titre d’indemnité.

8. Garantie

Les produits de QUINTESSENZA CERAMICHE sont garantis conformes aux normes UNI-EN en vigueur. L’Acheteur reconnaît que les variations de dimensions de fabrication, couleurs, nuances ou autres caractéristiques visuelles de la marchandise, même entre les carreaux de fond et les carreaux décorés, sont des caractéristiques des Produits et sont intrinsèques et inévitables, et que les échantillons du Vendeur ne sont qu’une approximation des Produits. En aucun cas, le Vendeur ne donnera, ou ne sera réputé avoir donné, une quelconque garantie, expresse ou implicite, en ce qui concerne toute déclaration, description ou illustration contenue dans toute brochure ou documentation. De plus, toute garantie écrite accordée par le Vendeur à l’Acheteur ne s’applique pas aux Produits de deuxième ou troisième choix ou aux lots occasionnels, mais est limitée uniquement aux Produits de premier choix, avec une tolérance d’environ 5 %. Lors de la réception des Produits, l’Acheteur devra les contrôler minutieusement en ouvrant la boîte. L’Acheteur assume la pleine et entière responsabilité de vérifier si les Produits sont conformes à ceux commandés ou s’ils conviennent à l’utilisation prévue par l’Acheteur, indépendamment de toute suggestion ou instruction donnée par le Vendeur concernant les Produits ou leur utilisation.

9. Réclamations

Les réclamations concernant les éventuelles quantités manquantes ou cassures doivent être adressées exclusivement au Transporteur (au moment du déchargement du matériel avec annotation sur le document de transport), en en informant immédiatement le Vendeur par écrit. Toute autre réclamation concernant la nature et/ou les caractéristiques du matériel devra être adressée au Vendeur par écrit et dans tous les cas dans les 8 jours suivant la réception de la marchandise. Passé ce délai, la marchandise est considérée comme vue et acceptée dans l’état dans lequel elle se trouve, sous peine de déchéance de la garantie. Les éventuels vices cachés de la marchandise devront être signalés selon les mêmes modalités que celles susmentionnées dans les 8 jours suivant leur découverte et dans tous les cas dans un délai d’un an à compter de la livraison, sous peine de déchéance de la garantie. Le client sera également déchu de la garantie si, après la déclaration effectuée en temps utile, il ne met pas le matériel à disposition du Vendeur ou s’il l’utilise. Les réclamations relatives au matériel déjà installé ne sont pas acceptées. Si des défauts sont constatés, le Vendeur peut, à sa discrétion, remplacer les Produits contestés ou annuler ou résilier le contrat, totalement en partie, sans obligation de remplacer les Produits. L’Acheteur renonce à toute autre réclamation, y compris, sans limitations, aux réclamations pour dommages directs, indirects, accidentels, consécutifs ou autres dommages ou compensations, ainsi qu’au droit d’annuler ou de résilier le contrat.

10. Traitement des données à caractère personnel

Confidentialité : la version intégrale peut être consultée au siège social de Quintessenza Ceramiche. Note d’information au sens de l’article 13 du décret législatif 196/2003. Les données sont traitées conformément à la loi aux termes des articles 7-8-9 du décret législatif 196/2003.

11. Droit applicable et juridiction compétente

Les contrats sont régis et interprétés conformément à la loi italienne. Pour toute contestation ou litige survenant entre les parties, le tribunal de Modène (Italie) sera le seul et unique compétent.

INSTALLATION AND MAINTENANCE GUIDE

EN

IMPORTANT

These instructions are a general guide for installing Quintessenza Ceramiche products.

Problems in a ceramic surface are hardly ever due to the ceramic product; they are usually due to a poor laying process, so please read and understand these instructions and check there is any problem related to defective tiles **before beginning to install our products**. We will not accept claims regarding installation costs on installed material.

I. Receiving the tiles

Open all boxes and check tiles before laying them.

If you are installing field tiles and special pieces or decors tiles, make sure that the colour shades of all products are compatible, bearing in mind that there might be slight shade differences that will not affect the final result.

II. Installation

1. Surface installation

This is the surface that you will apply the bonding material on.

The surface must be completely **clean** before starting the laying of the tiles.

Eliminate all remaining plaster, grease, wax, globs of mortar, organic substances and dust.

Any residue that is not eliminated will create weak bonding points that may generate future problems.

It is also necessary that the surface is perfectly **dry** (less than 3%), **vertical and flat**.

We also recommend you make sure there is no risk of rising damp in the laying surface.

The surface also has to have a good **cohesion**.

Finally, it is essential that the surface is stable, because surface shrinking, expansion or warping would be disastrous for the tiles.

Water-sensitive substrates (wood and chipboard, plaster and precast gypsum, etc.) may require a waterproofing primer.

If you are installing intermediate layers (insulation or waterproofing), check instructions for these products before starting tiling.

2. Selecting bonding materials

Always choose the best bonding material, according to the kind of surface you are tiling.

Anyway, it is always a good idea to ask to the manufacturer or distributor of the bonding material for the most suitable material to be used.

3. Tiling

3.1 Before you start

Do not hurry, do things slowly and safely, and arrange all materials and tools before starting the job. If this is the first time you have laid ceramic tiles, or you have limited experience, we recommend that you start tiling in a "hidden spot" (a part of the surface that will be covered by furniture, for example), as test area.

Basically, the tools you need are: meter, rule, level, carpenter's square, pails to prepare materials, notched trowel, rigid rubber plate, rubber hammer, rubber trowel, rigid sponges, cutter (manual or electric). And for your safety, at least: gloves, security glasses and steel toe boots.

All products and tools must be used according to the manufacturer's instructions.

During installation, the best weather conditions are:

- Temperature between 5 and 30 °C.
- Avoid rain or high humidity.
- Avoid risk of frost.
- Do not wet the surface until 48 hours after tiling.
- The temperature of the water used to prepare bonding materials is important, check the manufacturer's recommendations.

Do not use the thick-layer installation method; always install tiles following the thin-layer technique (3-5 mm thickness of bonding material layer).

In addition, for tiles that have a side of more than 30 cm long, it is highly recommended to use the double-bonding method (apply adhesive also to the back of the pieces), so the back of the tiles is completely covered by the bonding material.

Do not submerge the tiles in water before installation.

The laying joints must be at least 2 mm wide.

For locked layings of 25 cm-long tiles, displacement between tiles must be 1/3 maximum. Do not lay tiles with the joint the middle of their length.

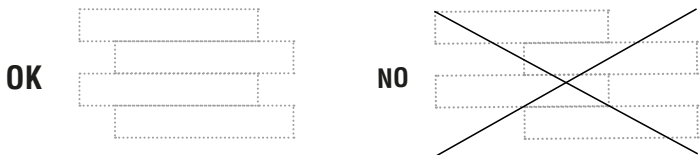

3.2 General planning and inspection

Usually actual measurements are quite different from dimensions shown in plans (sometimes even by several cm), so once the surface is completely clean check again all measurements, including gaps (windows, doors, etc.), and set the intermediate movement and expansion joints, if necessary.

These joints are essential in big surfaces greater than 8 m long (or 10 m2).

We also recommend the setting of perimeter joints in surfaces greater than 10 m2, specially for unstable surfaces (plasterboards, wood, metal, etc.). Anyway, floor tiles must be at least 5 mm away from the walls or any other element that might reduce settling movements.

3.3 Adhesive preparation

Prepare the fixing material, always following the manufacturer's instructions, using an electric low speed mixer, until you get a **homogeneous and lump-free paste, without bubbles**.

The adhesive manufacturer will inform you about the quantity you will need per square meter. Do not mix all the adhesive you will need at once; bear in mind that, once mixed, adhesives have a limited lifespan. Prepare only the quantity you can use during that lifespan.

A) CEMENT ADHESIVES (TYPE C)

- Always drop powder adhesive onto water (previously prepared in the mixing pail), and not water onto powder.
- If you notice hard lumps in the powder, do not use that sack of adhesive. It means that it was hydrated and might have lost its adhesive properties. For this same reason, do not keep adhesives for a long time once opened.
- Once the mix is done, **do not add more water, in any case and under any circumstances**.
- After mixing, wait for the resting time of the adhesive (set by manufacturer) before using it. After this time has passed, lightly stir the adhesive again.

B) REACTIVE RESINS (TYPE R)

- They usually consist of two separate ingredients. Mix them by pouring the lesser component (hardener) onto the large component (resin, previously prepared in the mixing pail).
- They usually do not require resting time

3.4 Laying the tiles

Apply the adhesive on the laying surface, using the straight side of the notched trowel, in a small area, for no more than 4 or 5 tiles, according to the open time of the adhesive (maximum time during which the adhesive can be used, from the moment it is applied).

Next, "comb" this adhesive, using the notched side of the trowel. The manufacturer of the adhesive must inform you about the most suitable kind of notched trowel to use. Usually a U6 (V6 for type D adhesives) is correct.

Comb the adhesive always creating straight lines, perpendicular to one side of the tiles.

This combing is important to get a uniform thickness of the adhesive layer, and to get a maximum contact of the back of the tiles with the adhesive.

If the back of the tiles is not completely covered by adhesive, this may cause problems in the future (tiles that fall off, grouting material that falls off, tiles that break when hit or drilled, etc.). Now it is time to lay the tile. Make sure that you do it before the open time of the adhesive finishes (if not, the back of the tiles may not be completely covered by adhesive).

Do not trust the open time given by the manufacturer, because it might change depending on the real atmospheric conditions you are working on. Check it from time to time, pulling up the last tile you have just laid to see if its back is really 100% covered by the adhesive.

Check every tile before laying it, to make sure it does not have any defect.

The best way to lay tiles is the so-called **Tarver Method**:

- For wall installation do not wet tiles before laying and apply adhesive also on the back of the tile, in the case of double-bonding, with the straight side of the notched trowel.
- Lay the tile more or less in its position, leaving at least a 2 mm wide joint.
- You can use tile cross spacers.
- **When laying non-rectified tiles of the same or different sizes, with different colours and/or gloss/matt finishes, even from the same collection, the grout should be used to compensate for any differences in calibre.**

Once the tile is in its position, check that it is in the same plane than the others, with no low or high corners. If necessary, use a clean rigid rubber plate, and hit it with a rubber hammer. Do any necessary correction of the position of the tiles during the adjust time of the adhesive. Never force a tile if it is hard to move, the only thing you will get is a poor adhesion of the tile, so it will easily fall off in the future.

Clean the excess of adhesive that accumulates in the spaces of the joints before it hardens, and also the adhesive on the glazed side of the tiles.

It is also important to remove the cross spacers before the bonding material hardens.

3.5 Metallic Colors

The special metallic glaze of these tiles is particularly acid-sensitive therefore we recommend before grouting to apply a sealer on the tiles (e.g. Fila MP90) and to wait 1 or 2 days for setting up the possible "crackle effect".

We do NOT recommend the installation of these tiles in showers, saunas or in any areas where water is expected to accumulate.

As a general rule, before and after grouting, never use abrasive sponges, scrubbers, blades or sharp objects that could scratch the surface of the tiles. **Anti-limescale products should not be used for ordinary maintenance**. We recommend using a natural cleaner such as Fila Cleaner. Complaints due to lack of care or fixing mistakes will not be accepted.

4. Selecting grouting materials (laying joints)

The kind of grouting material to use depends on the final use of the ceramic surface, and on the width of the joints. It is a good idea to ask the grouting material manufacturer about the more suitable product.

The most commonly used grouting materials are type GC2, but it depends on the type of adhesive you used to lay the tiles:

- If you used C1 adhesive (wall only), use CG1 grouting material.
- If you used C2 adhesive, use CG2 grouting material.
- If you used cement deformable adhesive (C1 or C2), or type D adhesive, use deformable grouting materials (CG S1 or S2).
- For R adhesives, use RG grouting material.

We recommend using waterproof (i.e.Fugalite Kerakoll Epoxy), anti-mildew grouting materials, especially for wet areas (showers, baths, etc.). Joints will be much easier to clean and maintain. In the areas where water is expected to accumulate (the border of the shower or bath, and the corners between walls), joints must be sealed with a continuous grout of silicone that is suitable for wet areas. If you do not use an epoxy grout, once the grout is dry, seal the grout joints with a penetrating or grout sealer equivalent to Fila Fugaproof. It is important to seal grout carefully, as if it is not completely sealed, moisture may be absorbed by the body of the tile, causing stains to appear through the glaze.

White grouting materials are usually used, but you can also use coloured grouts, matching the colour of the tiles or contrasting colour. We recommend spending some time trying different options; you will see how this substantially changes the final look of the ceramic surface. In any case, do not ever use materials coloured with black smoke (micronized coal), as they are very difficult to clean.

5. Grouting (laying joints)

5.1 Before you start

The grouting operation deserves as much care and skill as the laying of the tiles. The durability and aesthetic quality of the ceramic surface largely depends on this operation. So, again, do not hurry, do things slowly and safely, and arrange all materials and tools before starting the job.

If this is the first time you have laid ceramic tiles, or you have limited experience, we recommend that you start grouting in a "hidden spot" of the surface.

Use all products and tools according to the manufacturer's instructions.

Check that joints are empty and clean of bonding material, that they are dry (specially for RG materials), and that they have a uniform depth, equal to the thickness of the tiles. Wait for the time indicated by the manufacturer of the adhesive you used before starting grouting.

In order to get a uniform colour of all grouts once the job is done, try to use all the grouting material from the same production lot (it must all have the same lot code and date of production).

5.2 Grouting material preparation

For CG materials, use exactly the amount of water indicated by the manufacturer, and, as you did when preparing the adhesive, pour powder on water (not water on powder).

For RG materials pour liquid (minor ingredient) on paste (major ingredient).

Mix using an electric low speed mixer, until you get a homogeneous colour and texture.

As you did when preparing adhesive, do not prepare all the quantity of grouting material you will need at once (these materials also have a lifespan).

For CG materials, wait as indicated by the manufacturer once the mix is done before using it.

5.3 Grouting

Most manufacturers will show you on their web page how to apply grouting materials. We will describe the most common method.

Using a hard rubber trowel, distribute the material along the surface, always diagonally with respect to the joints. This way you will fill the joints with the grouting material uniformly, avoiding the edge of the trowel to get in the joints, and cleaning the tiles at the same time.

Sometimes RG materials are quite hard, so you might need steel spatulas or even an extruder. Use the appropriate tool to curve the surface of the joints. For narrow joints this is not necessary, you will get it when cleaning the joints before they harden.

5.4 Cleaning and finishing

A) CG MATERIALS

Once all joints are filled, clean them with water. **Wait for the time indicated by the manufacturer before cleaning the joints**.

Use a wet but well drained rigid sponge (it is better if it is attached to a trowel), rubbing the surface in circles. Clean the sponge with water and drain it as many times as necessary, and change the cleaning water when it starts to be turbid. It is very important that the sponge is always well drained, to avoid different shades of the grout and future efflorescences. You may need to do a second cleaning of the joints. If the first cleaning was done efficiently, this second cleaning can be done using just a dry cloth or suede.

B) RG MATERIALS

Cleaning is quite more difficult for these materials, so make sure that you understand the instructions given by the manufacturer before starting.Usually, these materials must be emulsified using water and special sponges, rubbing circles on the surface. Clean sponges very often.

6. Cutting and drilling

There is a wide range of tools to make all cuts and drilling you will need to install the tiles. In general, it is advisable to lay the cut pieces in the position where the cut is less visible.

The manual cutter is useful for most cuts, but does not guarantee high accuracy. Drilling for water intakes or drains should be done with electric drills, without striker, equipped with diamond-tipped drill bits, properly cooled by water. For square holes manual cutter can also be used (installing a special tungsten carbide punch), but is always easier to use an electric cutter. For special pieces (mouldings, torellos, etc.) use always an electric cutter.

III. Cleaning and maintenance

1. Cleaning after finishing laying works

When laying and grouting are finished, the ceramic surface may have a cement film on it.

If tiles have been laid on the floor, they will probably have a lot of dust over, so the first thing you should do is to carefully sweep all the surface.

In most cases (but not on metallic glazes), using a diluted acid solution (vinegar, for example) is enough to remove cement. There are also specific commercial products i.e. Fila /DETERDEK for cleaning and removing cementitious deposits or FILACR10 for cleaning epoxy grout residues, but they should be used with caution as they usually have higher acid concentrations. There are also specific commercial products i.e. Fila /DETERDEK for cleaning and removing cementitious deposits or FILACR10 for cleaning epoxy grout residues, but they should be used with caution as they usually have higher acid concentrations.

As a general rule, take always into account the following cautions:

- **Never use an acid product on recently installed tiles.**
- **Take special care with galvanized products** (gold, silver, bronze, etc.) as they are much less resistant to acids and aggressive cleaning products (see point 3.5.Metallic colors of the Installation Guide)
- **Carefully read and observe the instructions and recommendations given by the manufacturers of cleaning products.**
- Before using a cleaning agent, **test its effect on the ceramic tiles and grouts**.
- **Protect the surfaces where there are no ceramic tiles**, they may be affected by the cleaning product.
- **Never use scrubbers or abrasive sponges.**
- It is important to **always use clean water**. Change cleaning water every 15 m2 approximately.

To remove the protective wax in the glazed surface of tiles, **use only warm water and a damp cloth**. Do not use scrubbers, blades or sharp objects that could scratch the surface. If you used a porous grouting material, non waterproof, you may want to protect it with a **grout sealer**, specially if grouts are white of have a light colour.

2. Daily maintenance

It is very easy to maintain our tiles. Just **clean them usually with warm water or a dilute solution of a common detergent**.

Never use scrubbers, blades, sharp objects or abrasive sponges. It is important to always use clean water. Change the cleaning water every 25 m² approximately.If green or dark stains appear, it is usually due to humidity and fungus. Clean the tiles and grouts with bleach, and try to eliminate the source of humidity.

3. Extraordinary cleaning of stains and encrustations

In most cases, the use of household products is enough to eliminate the most common types of stains.

However, sometimes some products that have strong colourings may spill or come into contact by chance with the ceramic surface, producing spots or encrustations that can not be removed by normal cleaning operations.

In those cases, special cleaning agents and procedures must be used. The choice must be made with caution, taking into account the nature of the stain.

Before using a special cleaning agent, **test its effect on the ceramic tiles and grouts**, specially in the case of strong cleaning products (high concentrations) or solid detergents with abrasive particles.

Carefully read and observe the instructions and recommendations given by the manufacturers of cleaning products.

It is important to **always use clean water**. We recommend changing the cleaning water every 15 m2 approximately.

Protect the surfaces where there are no ceramic tiles, because the cleaning agents may damage certain materials such as wood, metals, etc.

CERTIFICAZIONI E SOSTENIBILITÀ AMBIENTALE

ENVIRONMENTAL SUSTAINABILITY AND CERTIFICATION
CERTIFICATIONS ET DURABILITÉ ENVIRONNEMENTALE



CERTICAZIONI AMBIENTALI

IT

I prodotti Quintessenza Ceramiche sono progettati per aiutare gli architetti a ottenere determinati punti o crediti assegnati dai sistemi di certificazione verde, facilitando così il processo di specifica dei materiali. Per ottenere questi sistemi di certificazione verde (LEED, BREEAM) vengono effettuati controlli da parte di terze parti e si certifica che i progetti edilizi sono stati progettati e realizzati utilizzando strategie concepite per migliorare gli aspetti ambientali chiave della loro progettazione. Tali aspetti includono: il risparmio energetico, il monitoraggio dei consumi idrici, la riduzione delle emissioni di CO2, il miglioramento della qualità ambientale interna dell'edificio, l'utilizzo di materiali riciclati, l'utilizzo di materie prime locali in prossimità dello stabilimento produttivo per abbattere i trasporti, ecc.

ENVIRONMENTAL CERTIFICATIONS

EN

Quintessenza Ceramiche products are designed to help architects obtain certain points or credits awarded by green certification systems, thus facilitating the material specification process. In order to obtain these green certification systems (LEED, BREEAM), third-party checks are carried out and it is certified that the building projects have been designed and implemented using strategies conceived to improve the key environmental aspects of their design. These aspects include: energy saving, monitoring water consumption, reducing CO2 emissions, improving the inner environmental quality of the building, the use of recycled materials, the use of local raw materials near the production plant to reduce transport costs, etc.

CERTIFICATIONS ENVIRONNEMENTALES

FR

Les produits Quintessenza Ceramiche sont conçus pour aider les architectes à obtenir certains points ou crédits attribués par les systèmes de certification environnementale, facilitant ainsi le processus de spécification des matériaux. Pour obtenir ces systèmes de certification environnementale (LEED, BREEAM), des contrôles sont effectués par des organismes tiers en vue de certifier que les projets de construction ont été conçus et mis en œuvre selon des stratégies visant à améliorer les aspects environnementaux clés de leur conception. Ces aspects comprennent : les économies d'énergie, la gestion efficace de l'eau, la réduction des émissions de CO2, l'amélioration de la qualité environnementale à l'intérieur du bâtiment, l'utilisation de matériaux recyclés, l'utilisation de matières premières locales à proximité de l'usine de production en vue de réduire les transports, etc.

VOC

VOC (COMPOSTI ORGANICI VOLATILI)

IT

Quintessenza Ceramiche certifica che tutti i prodotti ceramici che commercializza hanno valore zero per le Emissioni di Composti Organici Volatili (VOC) durante il loro ciclo di vita. Ciò è dovuto all'elevata temperatura (+1000°C) a cui vengono sottoposti tutti i nostri prodotti durante la cottura. Ad elevate temperature, ogni composto organico presente nelle materie prime viene completamente bruciato durante la produzione, quindi nessuna emissione organica può verificarsi durante il suo ciclo di vita.

VOC (VOLATILE ORGANIC COMPOUNDS)

EN

Quintessenza Ceramiche certifies that all the ceramic products it markets have zero Volatile Organic Compounds (VOC) Emission throughout their life cycle. This is due to the high temperature (+1000°C) which all our products are subjected to during firing. At high temperatures, every organic compound present in the raw materials is completely burned during production, so no organic emissions can occur throughout its life cycle.

COV (COMPOSÉS ORGANIQUES VOLATILS)

FR

Quintessenza Ceramiche certifie que tous les produits céramiques qu'elle commercialise sont à zéro émission de composés organiques volatils (COV) tout au long de leur cycle de vie. Ceci est dû à la température élevée (+1 000 °C) à laquelle tous nos produits sont soumis pendant la cuisson. À haute température, tout composé organique présent dans les matières premières est entièrement brûlé pendant la production, de sorte qu'aucune émission organique ne peut se produire pendant son cycle de vie.



MARCATURA CE

IT

La marcatura CE è la garanzia che determinati requisiti di sicurezza sono stati soddisfatti prima che un prodotto possa essere venduto. Tutte le piastrelle di ceramica in circolazione nell'Unione Europea devono essere conformi ai requisiti della marcatura CE, indipendentemente dalla qualità delle piastrelle. Ai sensi del regolamento europeo sui prodotti da costruzione, tutti i progetti edilizi devono essere pianificati ed eseguiti in modo tale da non compromettere la sicurezza delle persone, degli animali domestici o delle merci o danneggiare l'ambiente. Le piastrelle in ceramica di Quintessenza dispongono di una dichiarazione di prestazione DoP (precedentemente nota come dichiarazione di conformità) a disposizione di tutti i clienti che desiderano vederla. Contiene dettagli sulle prestazioni del prodotto in termini di criteri di sicurezza chiave (resistenza al fuoco, meccanica e allo scivolamento; emissioni di metalli pesanti; forza di adesione con diversi adesivi; durata, ecc.). Sulla confezione sono riportate informazioni riepilogative, unitamente alla marcatura CE.

CE MARKING

EN

CE marking is the guarantee that certain safety requirements have been met before a product can be sold. All ceramic tiles in circulation in the European Union must comply with CE marking requirements, regardless of tile quality. Pursuant to the European regulation on products for construction, all construction projects must be planned and executed in such a way so as not to compromise the safety of people, pets or goods or cause damage to the environment. Quintessenza ceramic tiles have a DoP declaration of performance (formerly known as a certification of conformity) available to all customers who wish to see it. It contains details on product performance in terms of key safety criteria (fire, mechanical and slip resistance; heavy metal emissions; bond strength with different adhesives; durability, etc.). The package contains summary information, in conjunction with the CE marking.

MARQUAGE CE

FR

Le marquage CE est la garantie que certaines exigences de sécurité ont été respectées avant qu'un produit puisse être vendu. Tous les carreaux de céramique en circulation dans l'Union européenne doivent être conformes aux exigences du marquage CE, quelle que soit la qualité des carreaux. Selon le règlement européen sur les produits de construction, tous les projets de construction doivent être conçus et exécutés de manière à ne pas compromettre la sécurité des personnes, des animaux domestiques ou des biens, ni à porter atteinte à l'environnement. Les carreaux céramiques de Quintessenza disposent d'une déclaration de performance DoP (auparavant appelée déclaration de conformité) à la disposition de tous les clients qui souhaitent la consulter. Celle-ci contient des détails sur les performances du produit en termes de critères de sécurité clés (résistance au feu, résistance mécanique et résistance à la glissance ; émissions de métaux lourds ; force d'adhésion avec différents adhésifs ; longévité, etc.). Des informations récapitulatives figurent sur l'emballage, tout comme le marquage CE.



IL MARCHIO UKCA (UK Conformity Assessed)

IT

Il marchio UKCA (UK Conformity Assessed) è il nuovo marchio del Regno Unito che sostituisce la marcatura CE ed è utilizzato per le merci immesse sul mercato della Gran Bretagna (Inghilterra, Galles e Scozia) dopo l'uscita del Regno Unito dall'Unione europea (Brexit). L'apposizione del marchio UKCA testimonia che il prodotto è conforme a tutti i requisiti legislativi del Regno Unito e che le procedure di valutazione della conformità sono state completate con successo. Tutti i prodotti Quintessenza Ceramiche risultano conformi ai requisiti richiesti.

UKCA MARKING (UK Conformity Assessed)

EN

The UKCA (UK Conformity Assessed) marking is the new UK marking that replaces the CE marking and is used for goods placed on the market of Great Britain (England, Wales and Scotland) after the United Kingdom left the European Union (Brexit). A product bearing the UKCA mark testifies that it complies with all UK legislative requirements and that the conformity assessment procedures have been successfully completed. All Quintessenza Ceramiche products comply with the necessary requirements.

LE MARQUAGE UKCA (UK Conformity Assessed)

FR

Le marquage UKCA (UK Conformity Assessed) est le nouveau marquage du Royaume-Uni qui remplace le marquage CE et est utilisé pour les produits mis sur le marché en Grande Bretagne (Angleterre, Pays de Galles et Écosse) après la sortie du Royaume-Uni de l'Union européenne (Brexit). L'apposition du marquage UKCA atteste que le produit est conforme à toutes les exigences législatives du Royaume-Uni et que les procédures d'évaluation de la conformité ont été menées à bien. Tous les produits Quintessenza Ceramiche sont conformes aux exigences requises.



MATERIALE RICICLATO

IT

Le piastrelle di Quintessenza Ceramiche sono prodotte in stabilimenti in cui si ottimizza la gestione dell'acqua nei diversi processi della fase produttiva. Inoltre c'è un impegno costante dell'ottimizzazione dell'applicazione di criteri di efficienza energetica nelle strutture dedicate.

L'impasto ceramico utilizzato per la produzione delle ceramiche firmate Quintessenza è costituito per almeno un 39% di Recycled content per quanto riguarda il gres porcellanato e per almeno un 34% per quanto riguarda la pasta bianca.

RECYCLED MATERIAL

EN

Quintessenza Ceramiche tiles are produced in factories where water management is optimized in the various processes of the production phase. Moreover, we are constantly committed to optimizing the application of energy efficiency criteria in dedicated facilities.

The body used for the production of Quintessenza ceramic is made up of at least 39% Recycled content for porcelain stoneware and at least 34% for white body.

MATÉRIAU RECYCLÉ

FR

Les carreaux de Quintessenza Ceramiche sont fabriqués dans des usines où la gestion de l'eau est optimisée dans les différents processus de production. Par ailleurs, nous nous efforçons constamment d'optimiser l'application des critères d'efficacité énergétique dans les installations dédiées.

La pâte céramique utilisée pour la fabrication des céramiques signées Quintessenza est constituée d'au moins 39% de matières recyclées en ce qui concerne le grès cérame et d'au moins 34% pour la pâte blanche.



DICHIARAZIONE AMBIENTALE DEL PRODOTTO - EN ISO 14025:2010

IT

Quintessenza Ceramiche garantisce l'eccellenza ambientale dei prodotti ceramici che viene attestata attraverso le dichiarazioni ambientali di prodotto (EPD) secondo la normativa internazionale ISO 14025, che definisce i requisiti che le dichiarazioni ambientali devono soddisfare. Le dichiarazioni ambientali di prodotto (EPD) forniscono informazioni che garantiscono un profilo ambientale affidabile, pertinente, trasparente, comparabile e verificabile. Dati essenziali per evidenziare il fatto che il prodotto rimane ecologico durante tutto il suo ciclo di vita (LCA) in conformità con gli standard internazionali.

ENVIRONMENTAL PRODUCT DECLARATION - EN ISO 14025:2010

EN

Quintessenza Ceramiche guarantees the environmental excellence of the ceramic products which is certified through environmental product declarations (EPDs) according to the ISO 14025 international standard, which defines the requirements that must be met by environmental declarations. Environmental Product Declarations (EPDs) provide information that ensures a reliable, relevant, transparent, comparable and verifiable environmental profile. This essential data highlights the fact that the product remains ecological throughout its life cycle (LCA) in accordance with international standards.

DÉCLARATION ENVIRONNEMENTALE DE PRODUIT - EN ISO 14025:2010

FR

Quintessenza Ceramiche garantit l'excellence environnementale de ses produits céramiques, qui est certifiée par des déclarations environnementales de produit (DEP) conformes à la norme internationale ISO 14025 et définissant les exigences auxquelles les déclarations environnementales doivent répondre. Les déclarations environnementales de produits (DEP) fournissent des informations qui garantissent un profil environnemental fiable, pertinent, transparent, comparable et vérifiable. Ces données sont essentielles pour mettre en évidence le fait que le produit reste respectueux de l'environnement tout au long de son cycle de vie (ACV), conformément aux normes internationales.

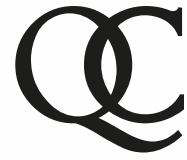

CREDITS

ART DIRECTOR QC
Ramona Macchi

MARKETING COORDINATOR
Diletta Levrini

GRAPHIC PROJECT
discromie.com

PHOTOGRAPHY
Elodie Cavallaro

PRINTING
Spazio Stampa

AVVERTENZE:

I colori dei prodotti ceramici riportati su questo catalogo sono da ritenersi puramente indicativi. Consigliamo di visionare sempre il prodotto reale. Le tabelle con i dati di imballo e le caratteristiche tecniche sono aggiornate al momento della stampa del catalogo, pertanto i dati indicati possono subire delle variazioni.

AVVERTENZE:

The colours of the tiles products shown in this catalogue are to be considered purely indicative. We recommend always viewing the actual product. The tables with the Packing data are updated at the catalogue printing time, therefore the listed data can be altered.

AVERTISSEMENTS:

Les couleurs des produits céramiques présentés dans ce catalogue doivent être considérées comme purement indicatives. Nous vous recommandons de toujours visualiser le produit réel. Les tableaux avec les informations sur l'emballage et les caractéristiques techniques sont mis à jour au moment de l'impression du catalogue, donc les informations indiquées peuvent être sujettes à des variations.



QUINTESSENZA
— CERAMICHE —